

CHARLOTTE

50,60,80 UC / 450
50,60,80 UDC / 450

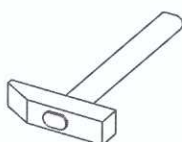

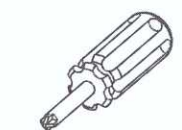

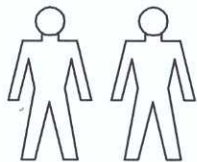
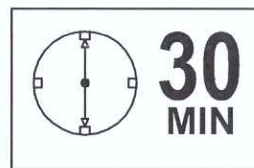
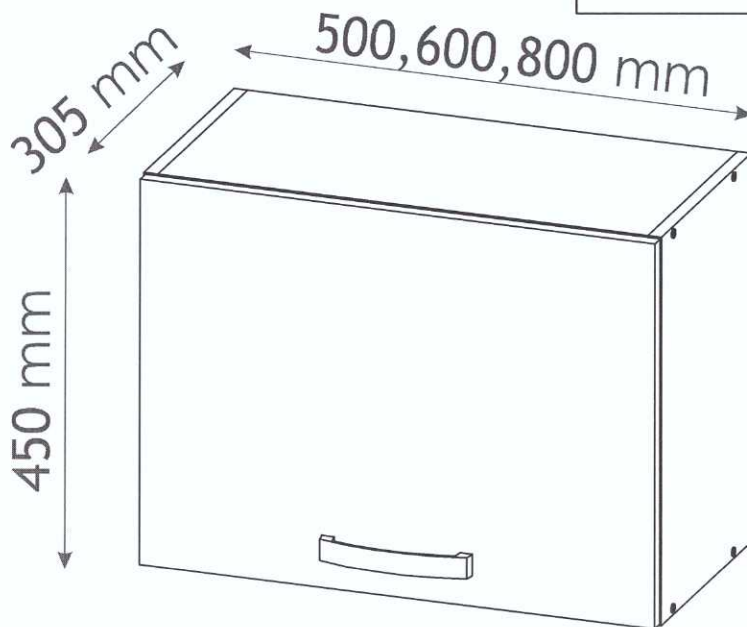



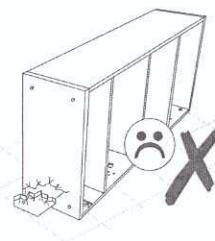
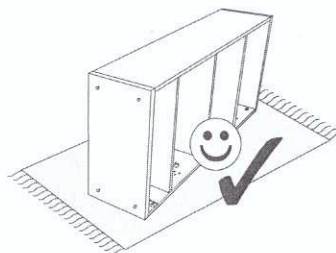
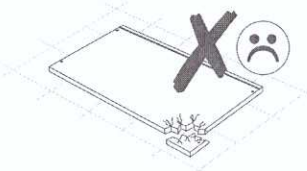
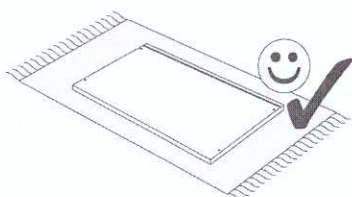
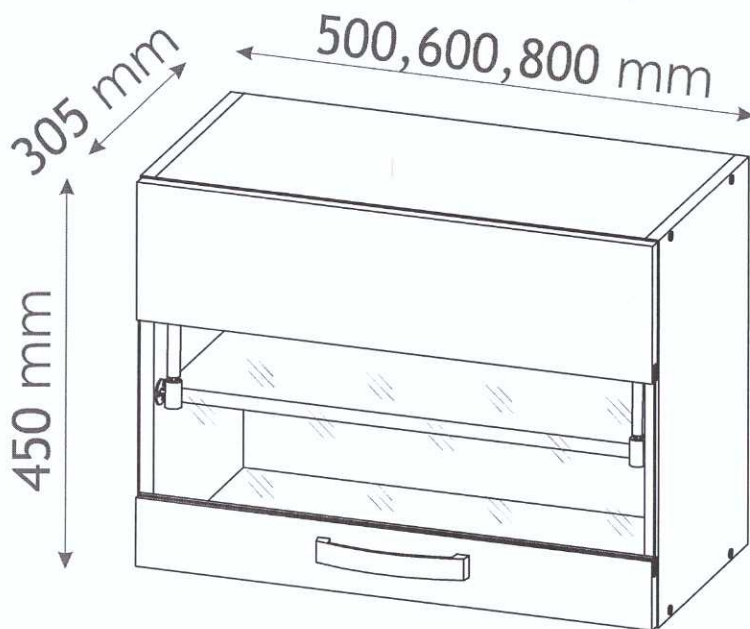





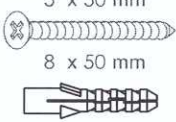

A

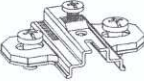
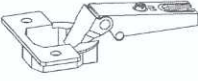
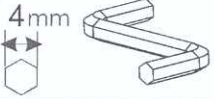

B

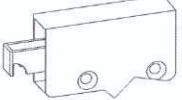

CHARLOTTE 50,60,80 UC / 450 50,60,80 UDC / 450

| | | |
|---|--|--|
| A0 8 x 32mm x4  | B1 f 7 x 50 mm x8  | B0 x4  |
| D10 4 x 16 mm x4  | D13 4 x 30 mm x4  | E0 x4 5 x 50 mm 8 x 50 mm  |
| F1 x2  | H0 x2  | H2 4 x 22 mm x2  |
| J6 x2  | J8 x2  | K x1 4mm  |
| L22 x1  | P4 x2  | P5 x2  |
| Q0 x4  | T8 x25  | |

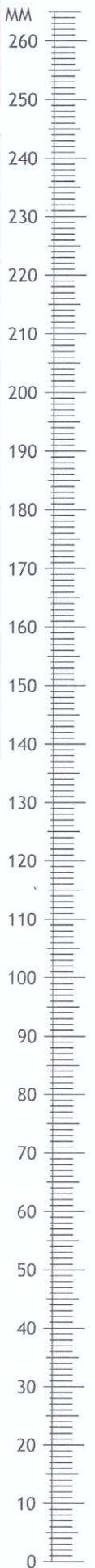

CHARLOTTE

50,60,80 UC / 450
50,60,80 UDC / 450

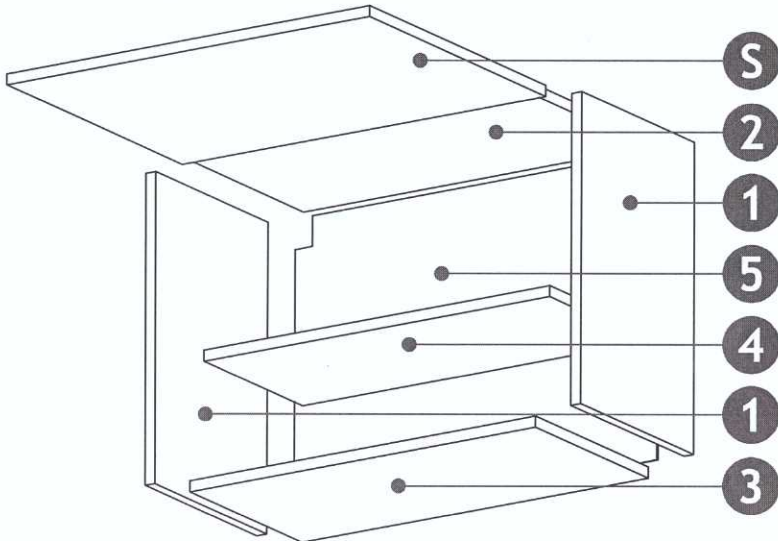

500

| | | | | | |
|-----|-----|-----|-----|----|-----|
| ① | 450 | 285 | 16 | x2 | 1/1 |
| ② | 467 | 285 | 16 | x1 | 1/1 |
| ③ | 467 | 285 | 16 | x1 | 1/1 |
| ④ | 466 | 250 | 16 | x1 | 1/1 |
| | | | | | 1/1 |
| ⑤ | 495 | 445 | 2.5 | x1 | 1/1 |
| D S | 497 | 446 | 16 | x1 | 1/1 |

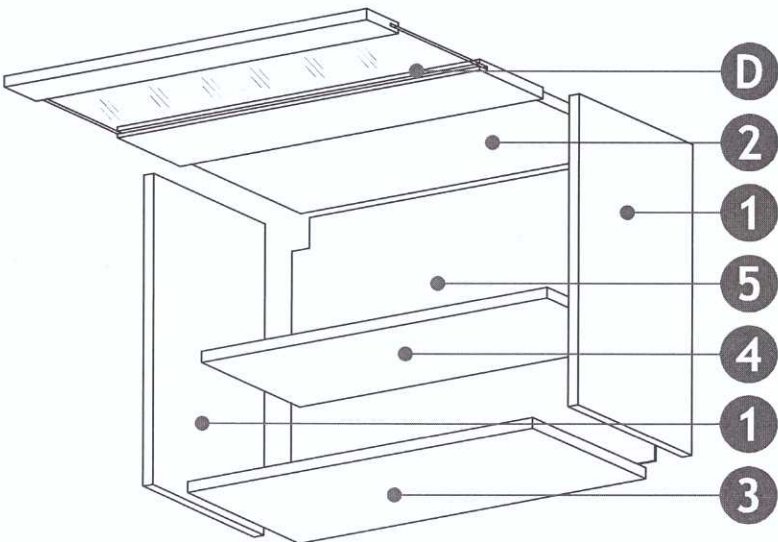

600

| | | | | | |
|-----|-----|-----|-----|----|-----|
| ① | 450 | 285 | 16 | x2 | 1/1 |
| ② | 567 | 285 | 16 | x1 | 1/1 |
| ③ | 567 | 285 | 16 | x1 | 1/1 |
| ④ | 566 | 250 | 16 | x1 | 1/1 |
| | | | | | 1/1 |
| ⑤ | 595 | 445 | 2.5 | x1 | 1/1 |
| D S | 597 | 446 | 16 | x1 | 1/1 |

800

| | | | | | |
|-----|-----|-----|-----|----|-----|
| ① | 450 | 285 | 16 | x2 | 1/1 |
| ② | 767 | 285 | 16 | x1 | 1/1 |
| ③ | 767 | 285 | 16 | x1 | 1/1 |
| ④ | 766 | 250 | 16 | x1 | 1/1 |
| | | | | | 1/1 |
| ⑤ | 795 | 445 | 2.5 | x1 | 1/1 |
| D S | 797 | 446 | 16 | x1 | 1/1 |

1 ▶

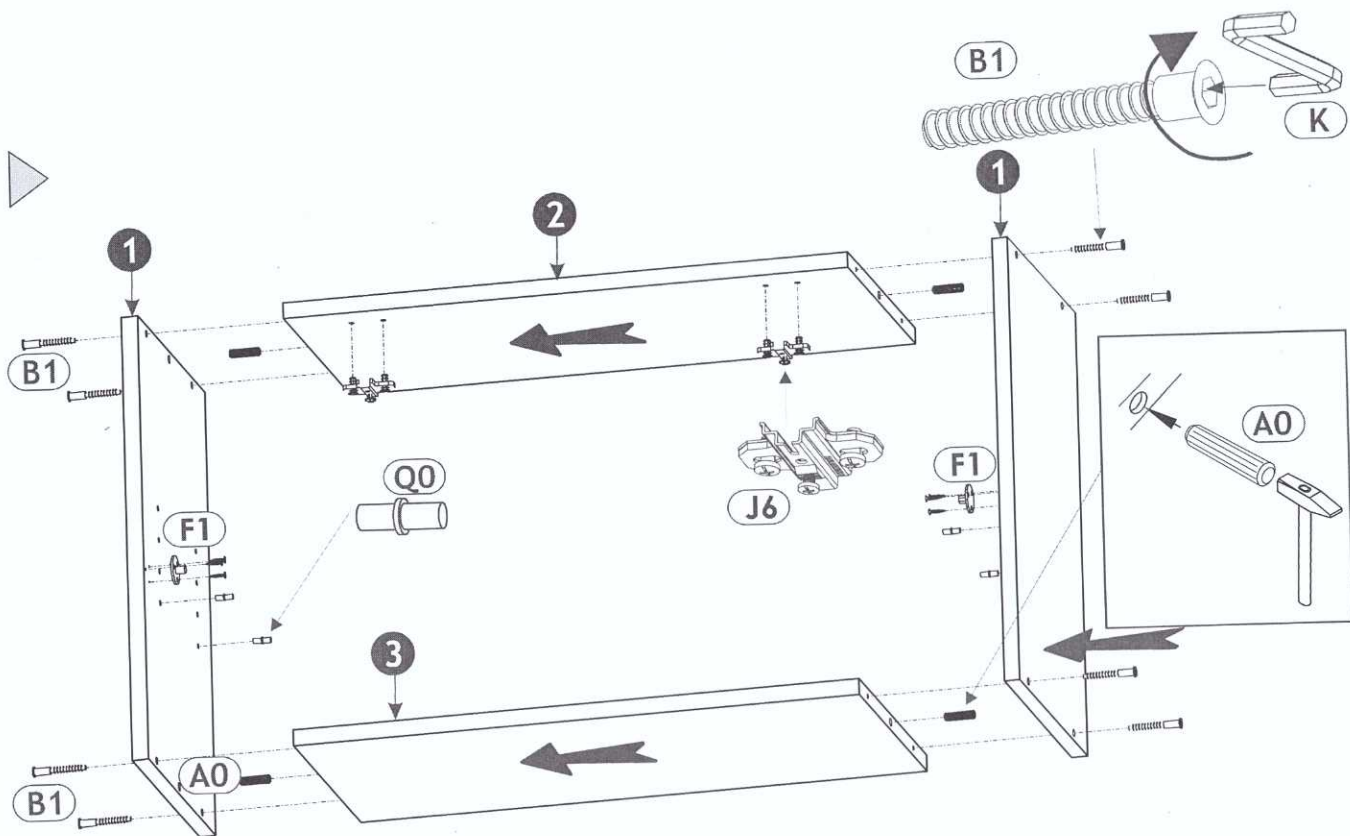

2 ▶

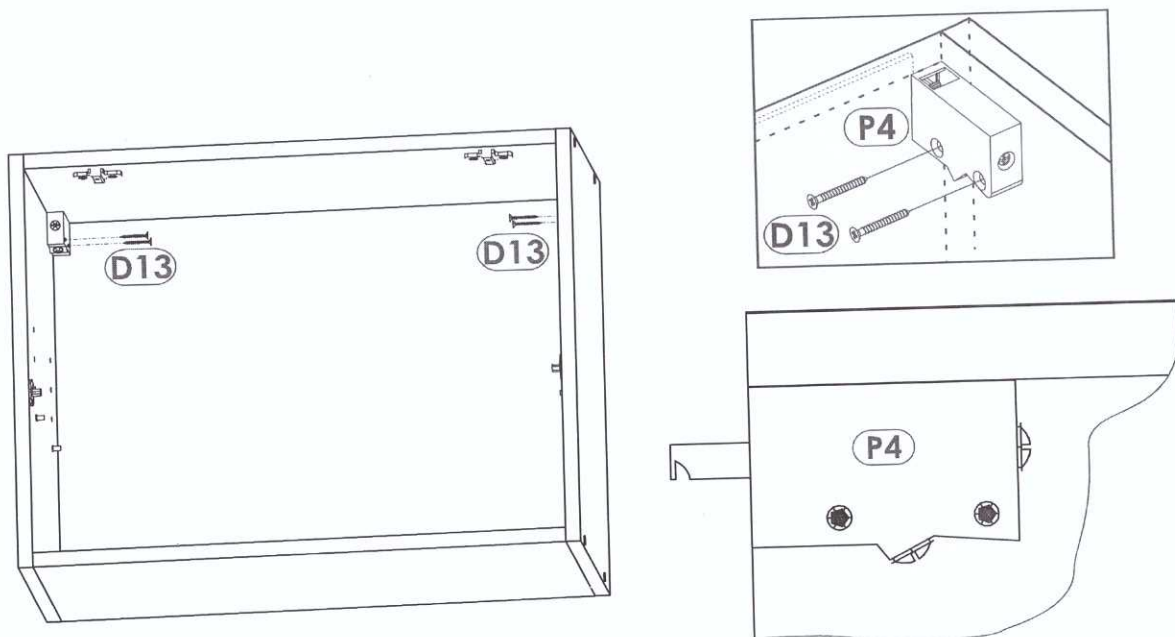

3 ▶

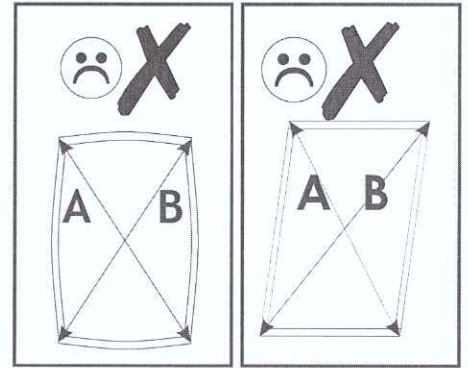
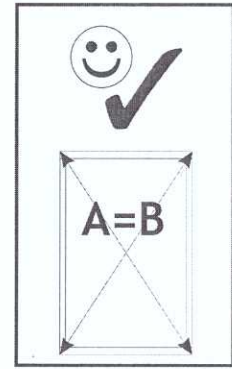
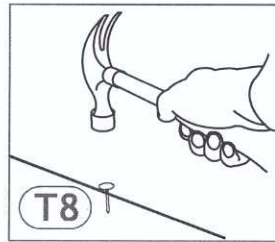
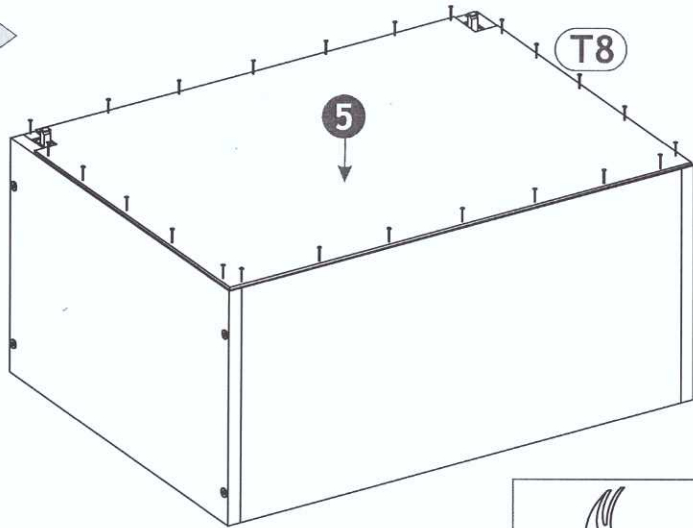

4 ▶ A

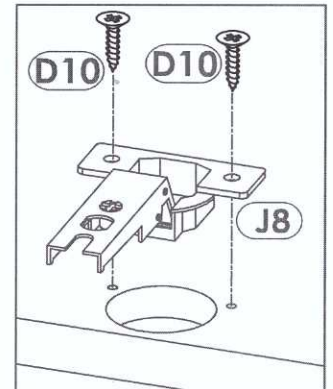
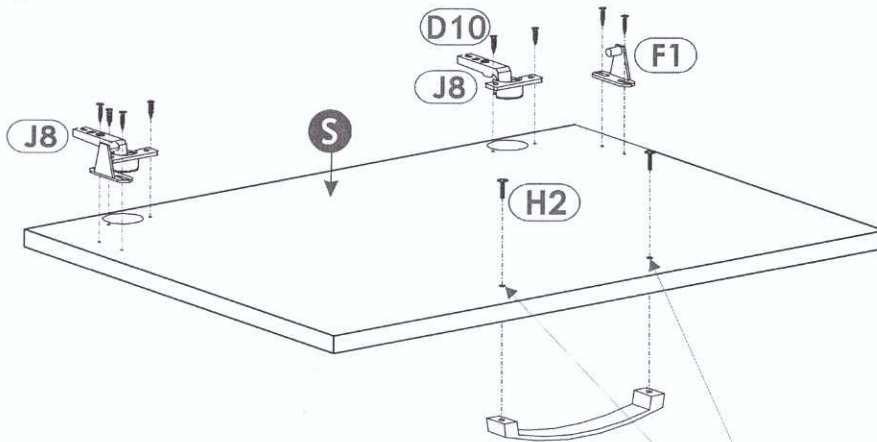

4 ▶ B

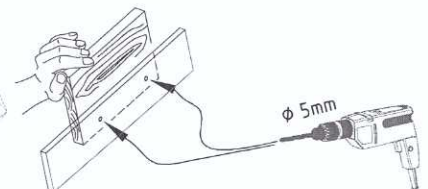
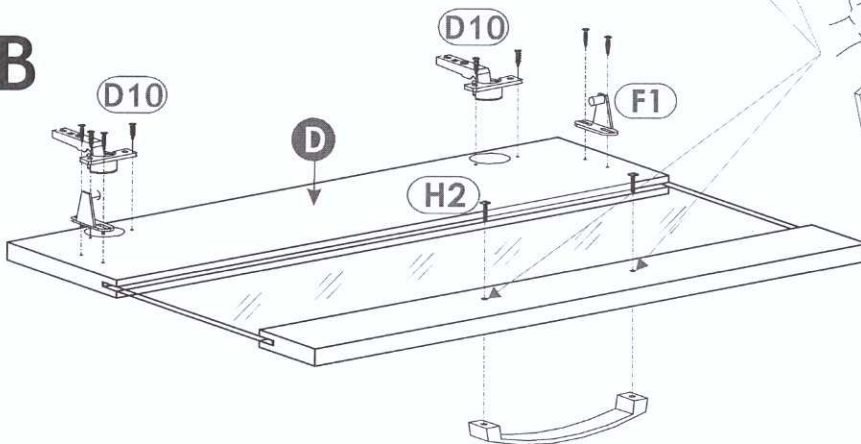

5 ▶ A

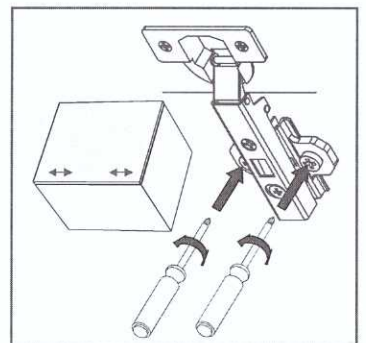
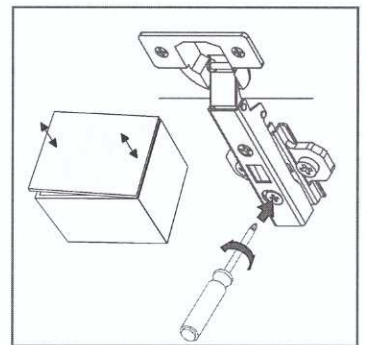
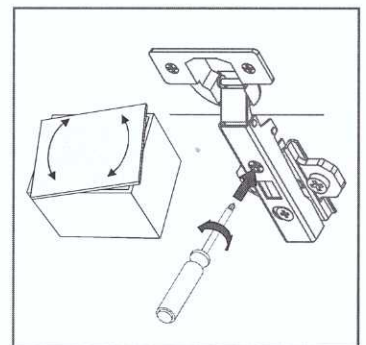
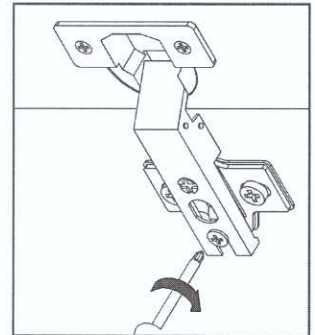
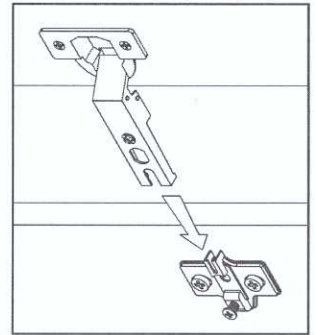
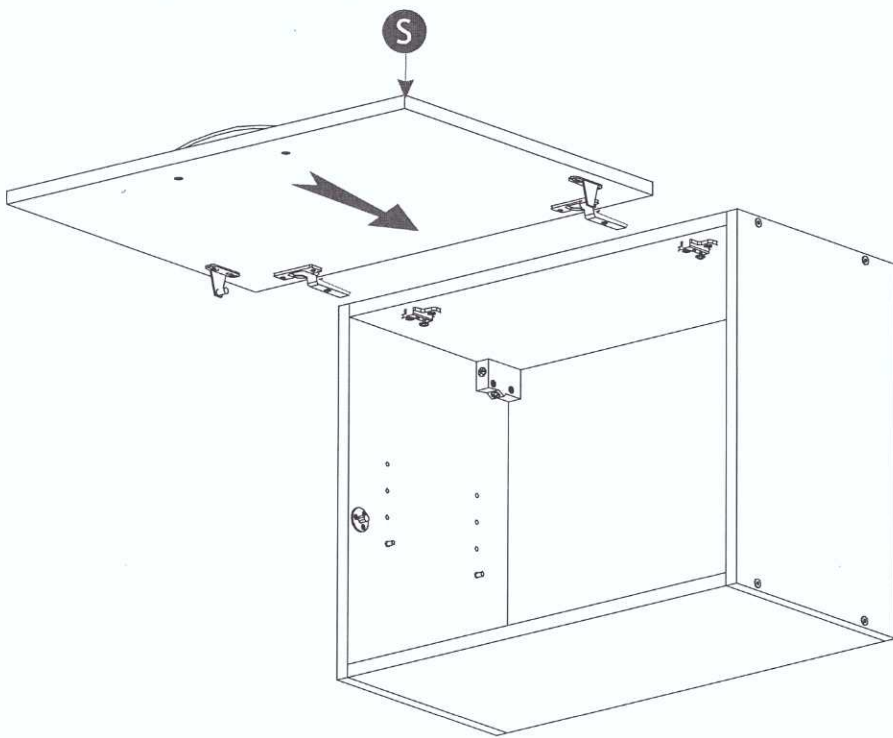

5 ▶ B

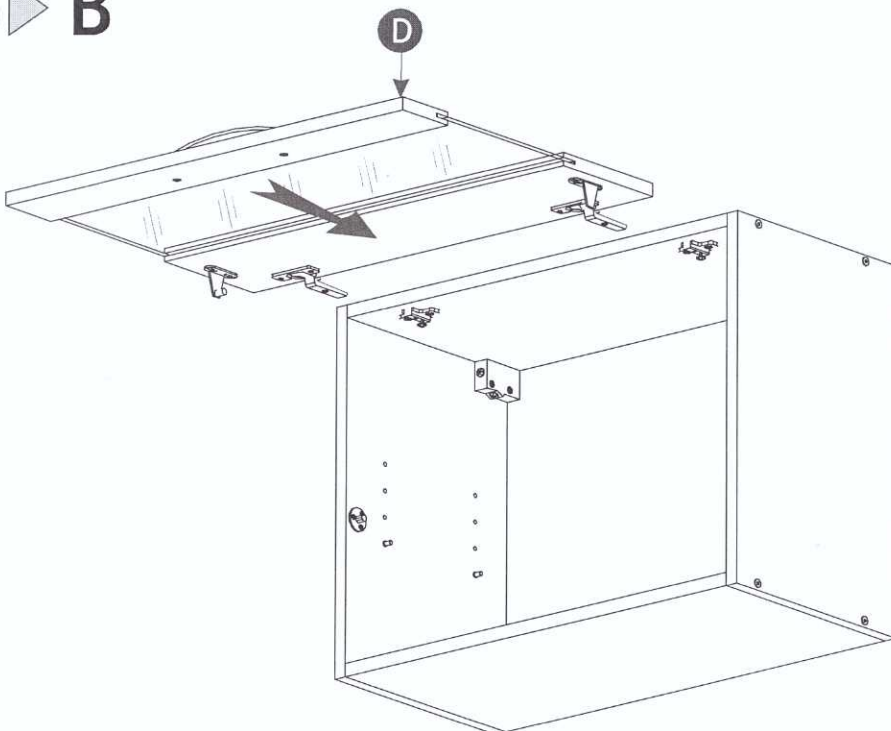

6 ▶ A

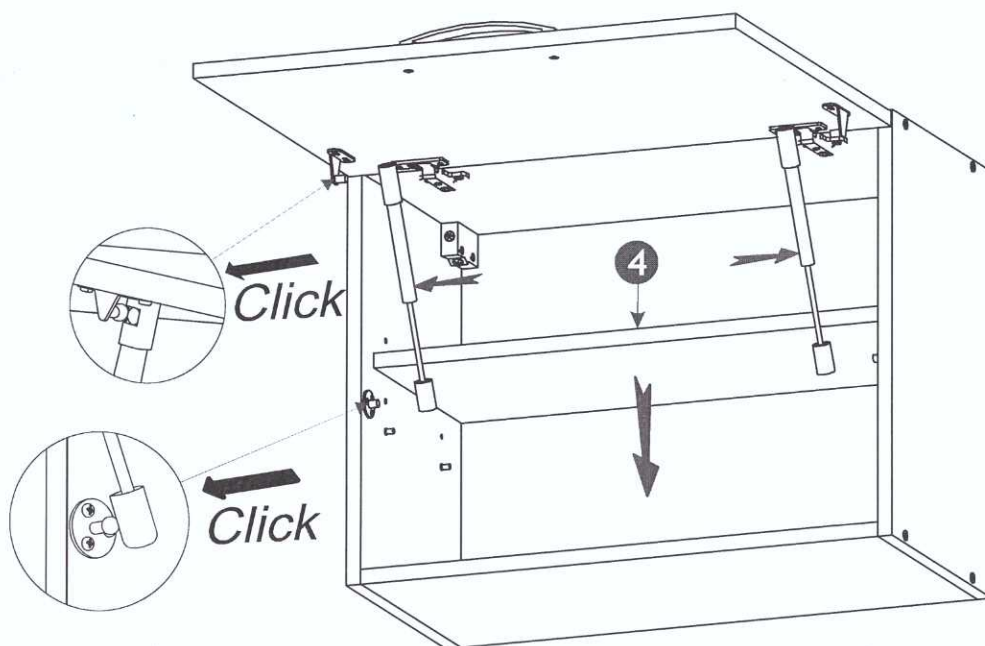

6 ▶ B

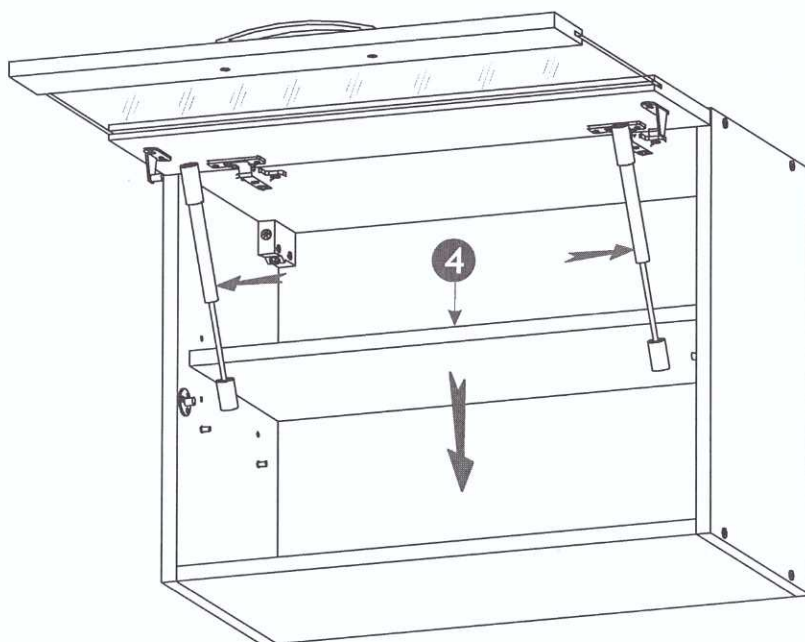

7 ▶

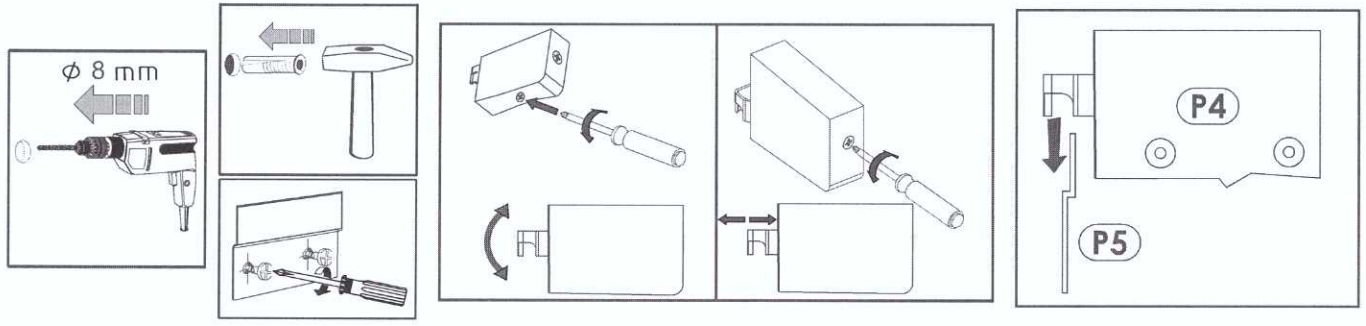
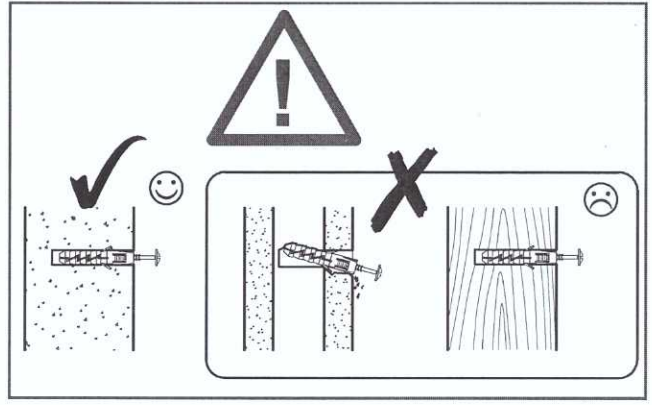
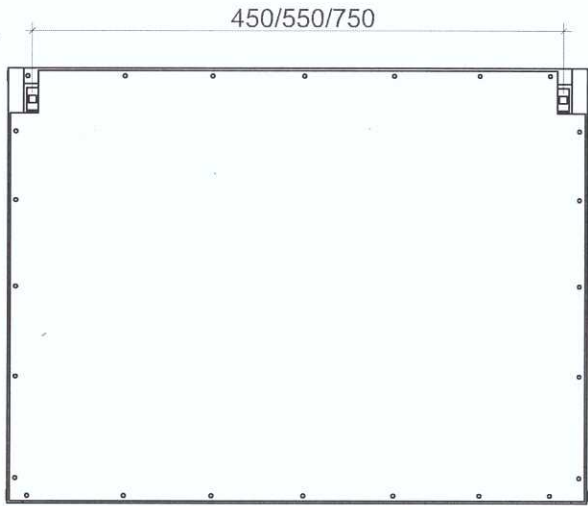

8 ▶

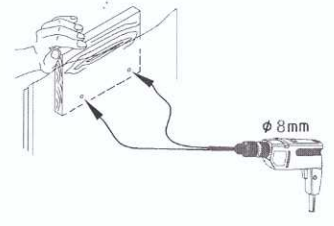
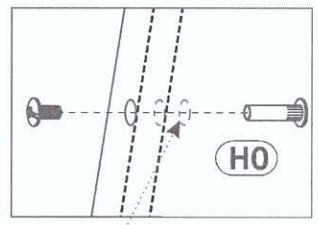
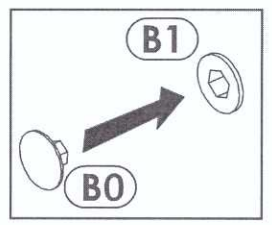
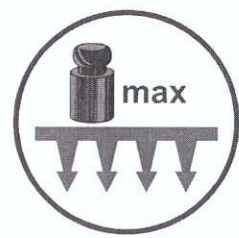
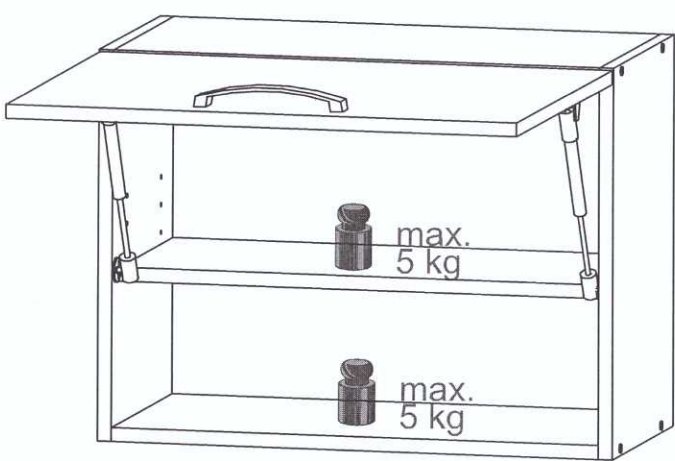

CHARLOTTE 60,80 UC 60,80 UDC

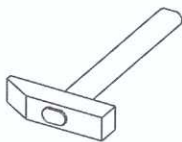
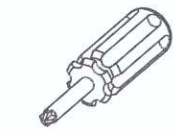
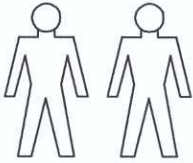
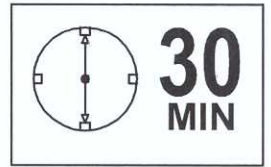



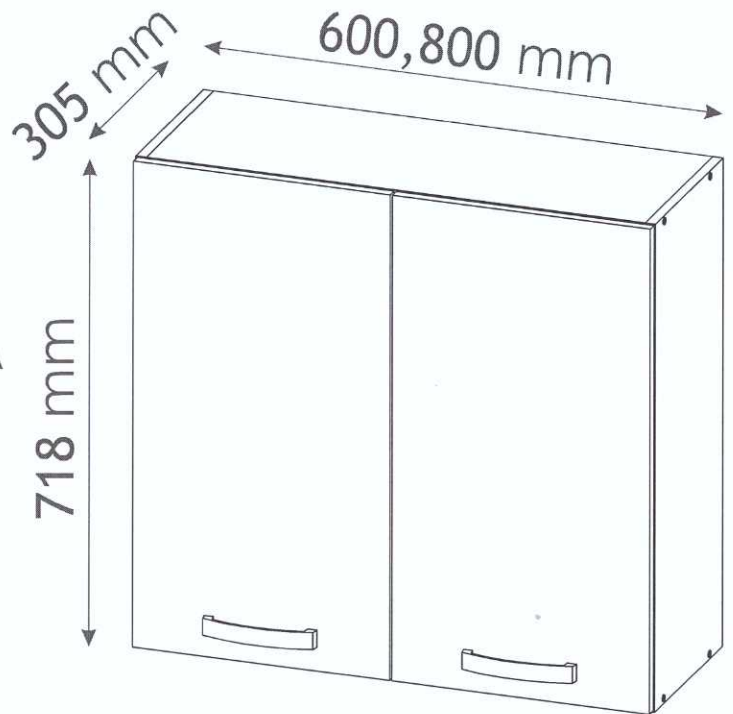



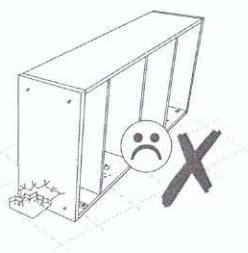
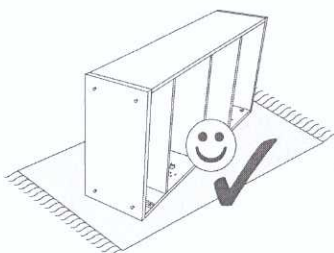
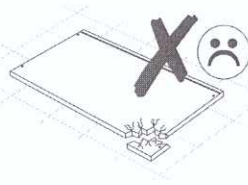
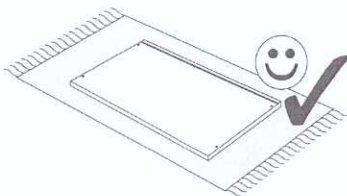
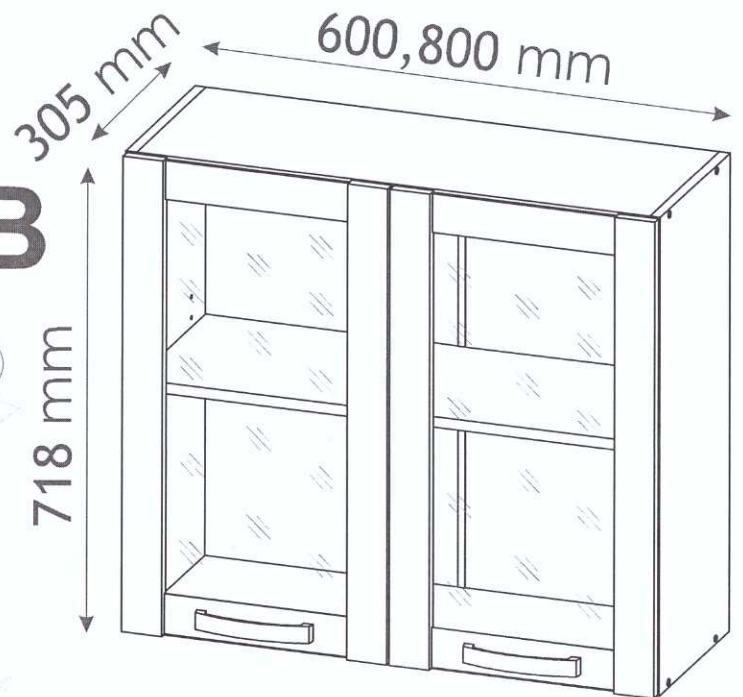





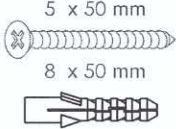

A

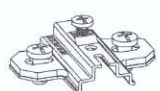

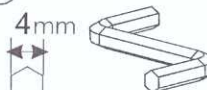
B

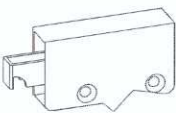



CHARLOTTE 60,80 UC 60,80 UDC

| | | |
|--|---|--|
| A0 8 x 32mm x4  | B1 f 7 x 50 mm x8  | B0 x4  |
| D10 4 x 16 mm x8  | D13 4 x 30 mm x4  | E0 5 x 50 mm 8 x 50 mm x4  |
| H0 x2  | J6 x4  | J8 x4  |
| K 4mm x1  | L22 x2  | P4 x2  |
| P5 x2  | Q0 x4  | R5 x1 L- 685mm.  |
| T8 x40  | | |

60,80 UC

| |
|---|
| H2 4 x 22 mm x4  |
|---|

60,80 UDC

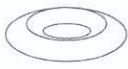
| | |
|---|--|
| H7 4 x 10 mm x4  | U1 x4  |
| U3 x4  | |

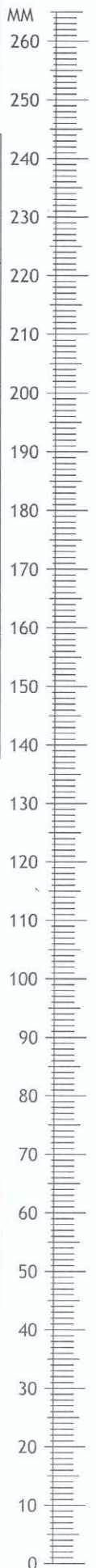

CHARLOTTE 60,80 UC 60,80 UDC

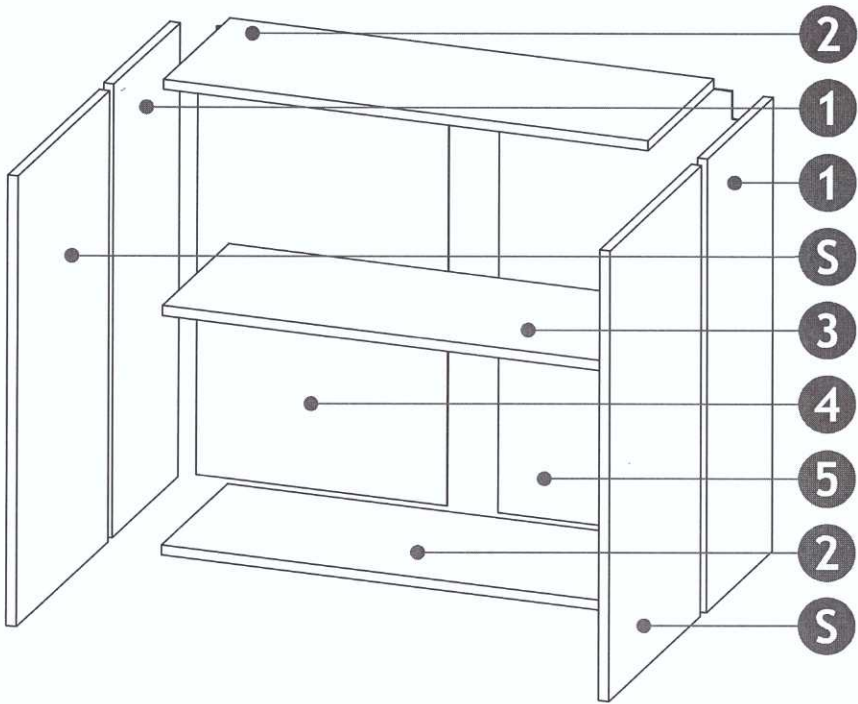

600

| | | | | |
|---|-----|-----|--------|-----|
| 1 | 718 | 285 | 16 x2 | 1/1 |
| 2 | 567 | 285 | 16 x2 | 1/1 |
| 3 | 566 | 280 | 16 x1 | 1/1 |
|  | | | | 1/1 |
| 4 | 713 | 297 | 2.5 x1 | 1/1 |
| 5 | 713 | 297 | 2.5 x1 | 1/1 |
| D S | 714 | 297 | 16 x2 | 1/1 |

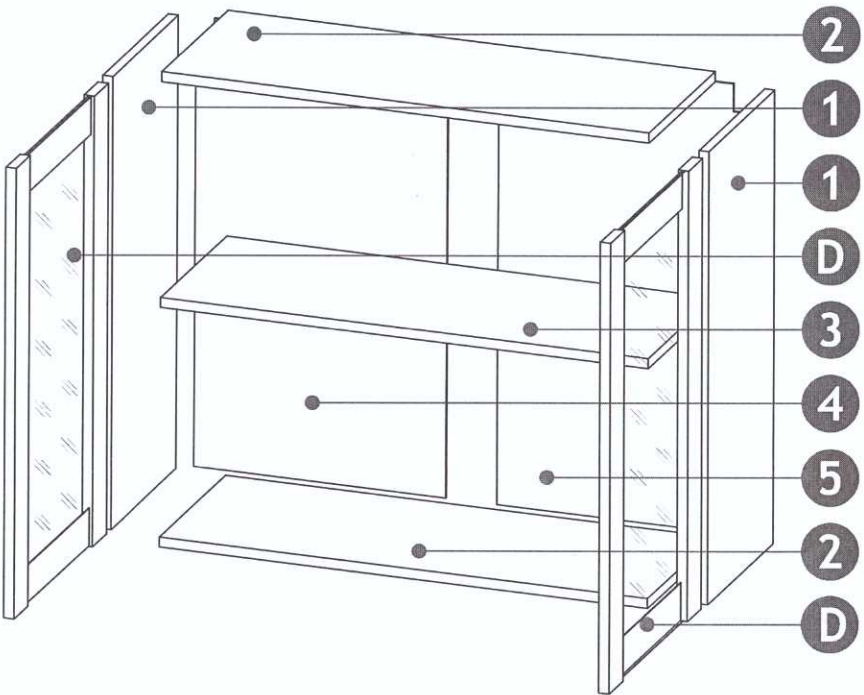

800

| | | | | |
|---|-----|-----|--------|-----|
| 1 | 718 | 285 | 16 x2 | 1/1 |
| 2 | 767 | 285 | 16 x2 | 1/1 |
| 3 | 766 | 280 | 16 x1 | 1/1 |
|  | | | | 1/1 |
| 4 | 713 | 397 | 2.5 x1 | 1/1 |
| 5 | 713 | 397 | 2.5 x1 | 1/1 |
| D S | 714 | 397 | 16 x2 | 1/1 |

1 ▶

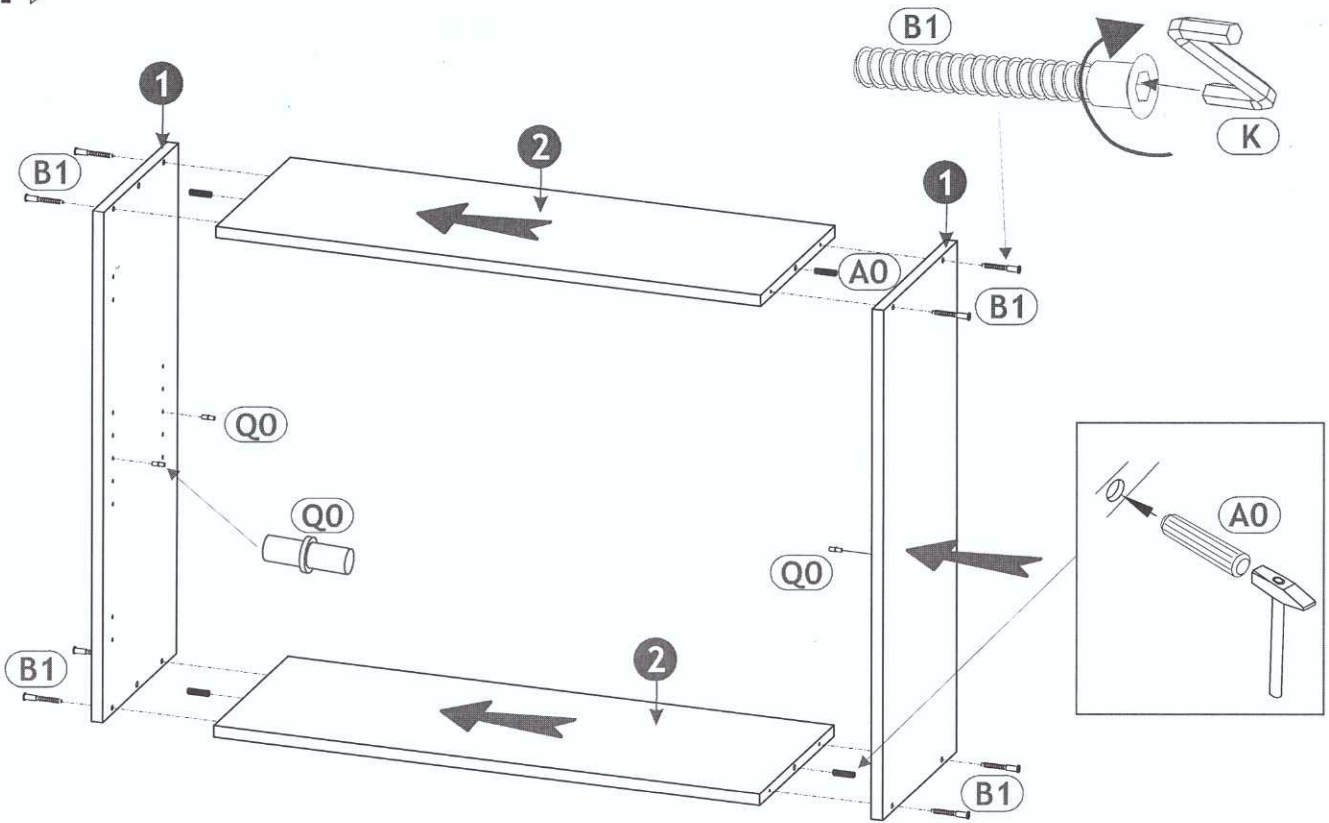

2 ▶

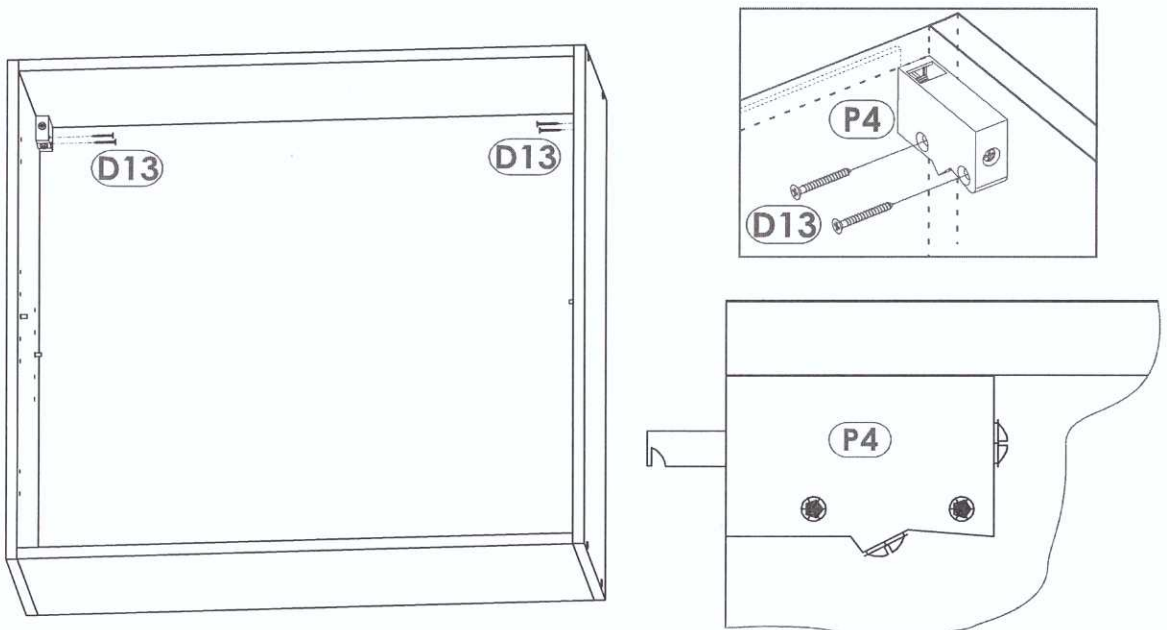

3 ▶

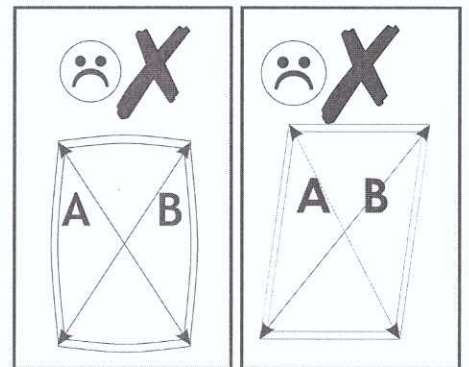
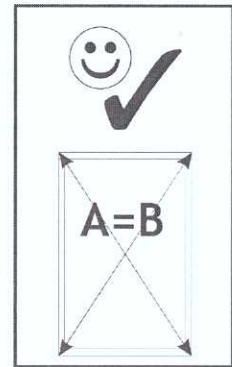
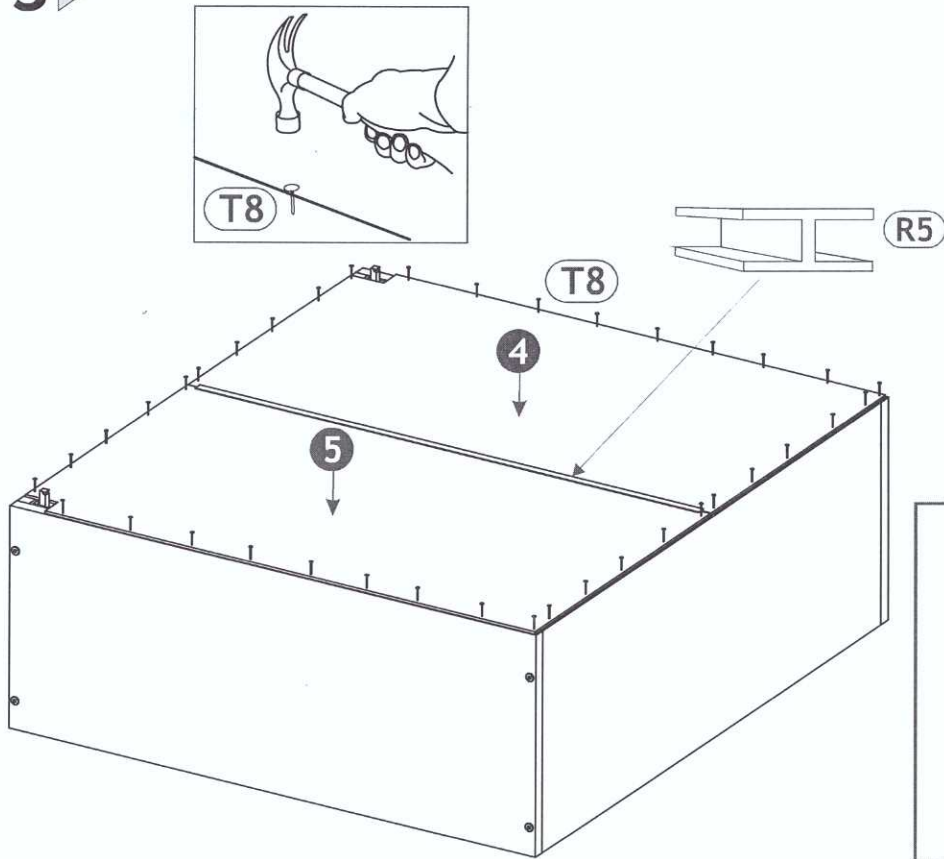

4 ▶ A

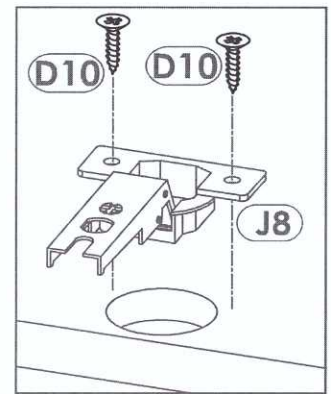
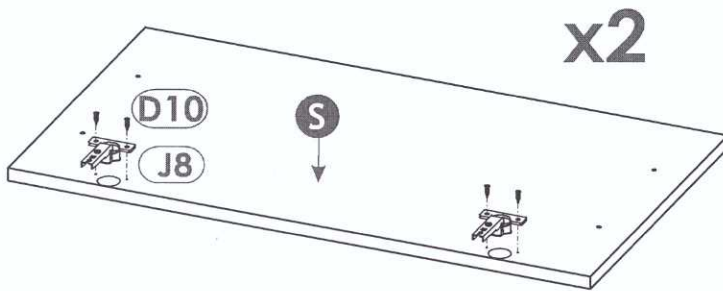

4 ▶ B

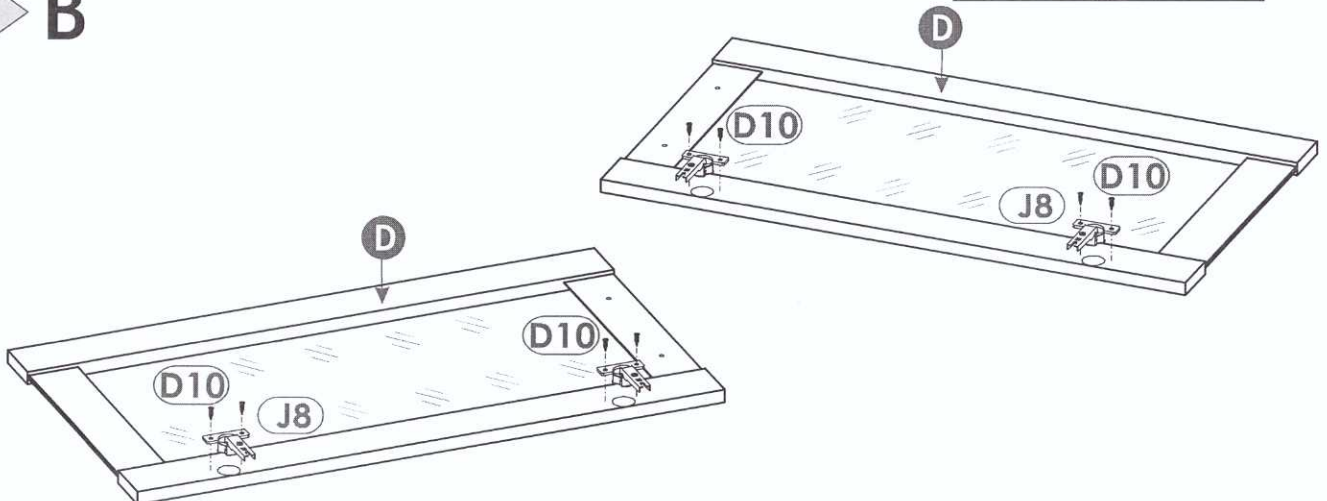

5 ▶ A

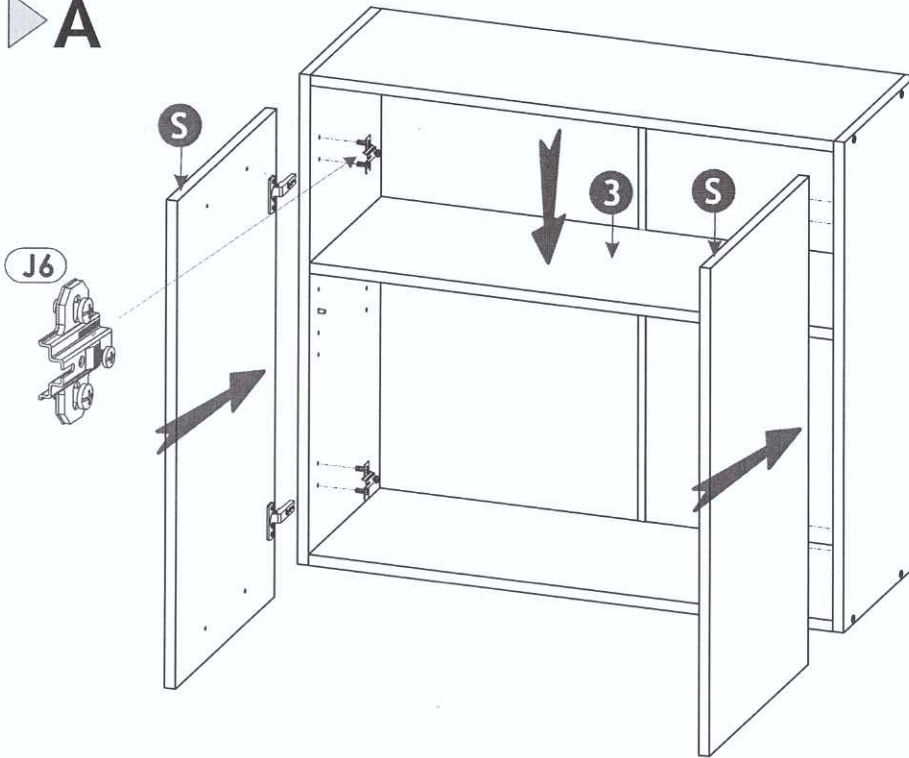

5 ▶ B

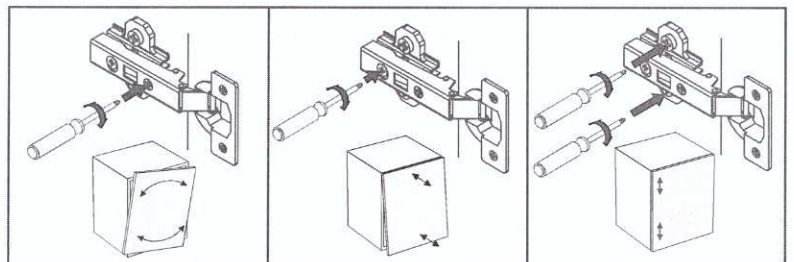
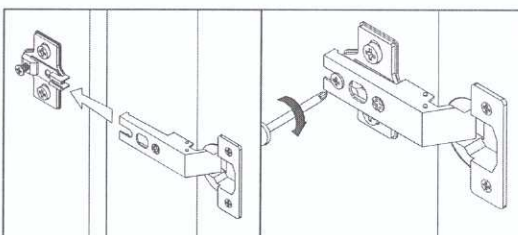
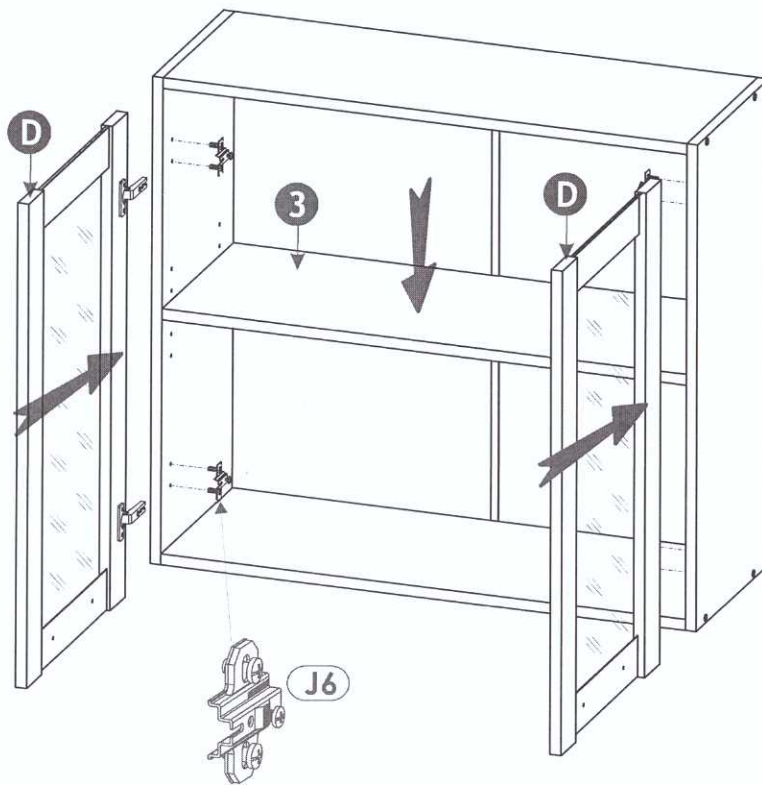

6 ▶ A

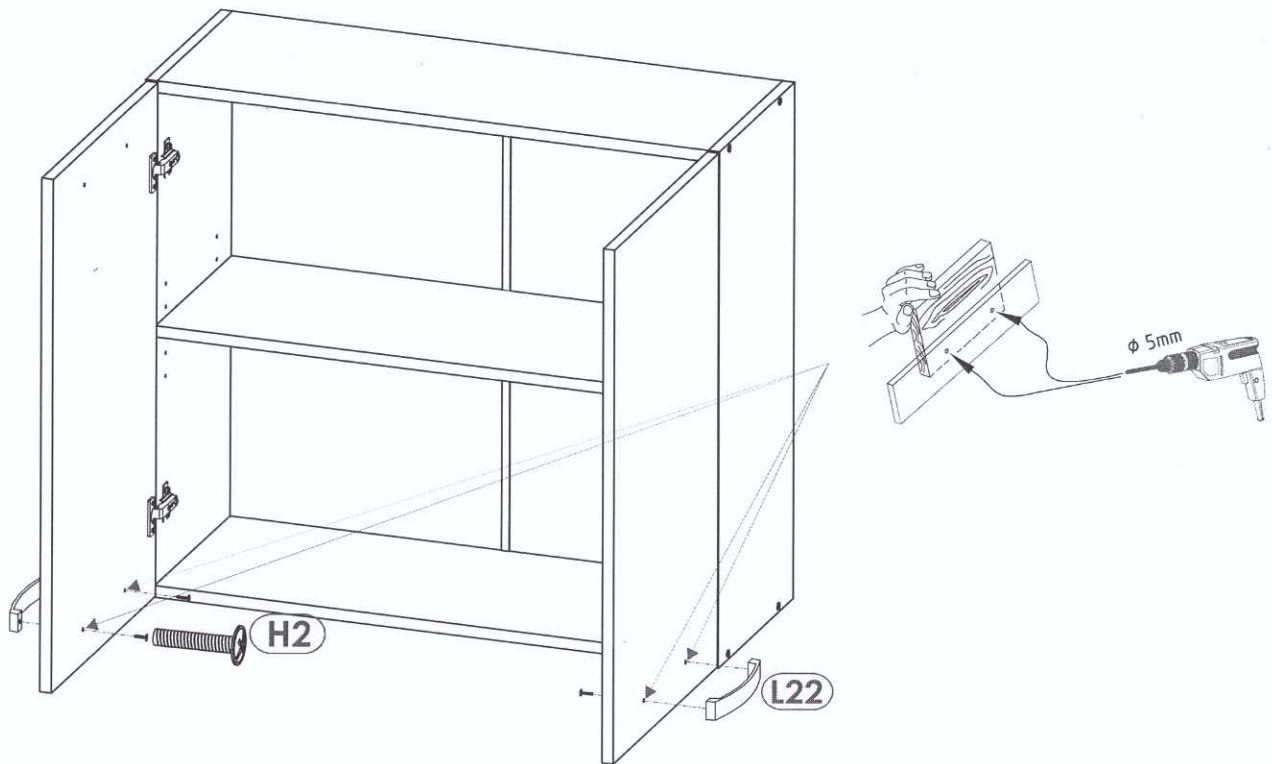

6 ▶ B

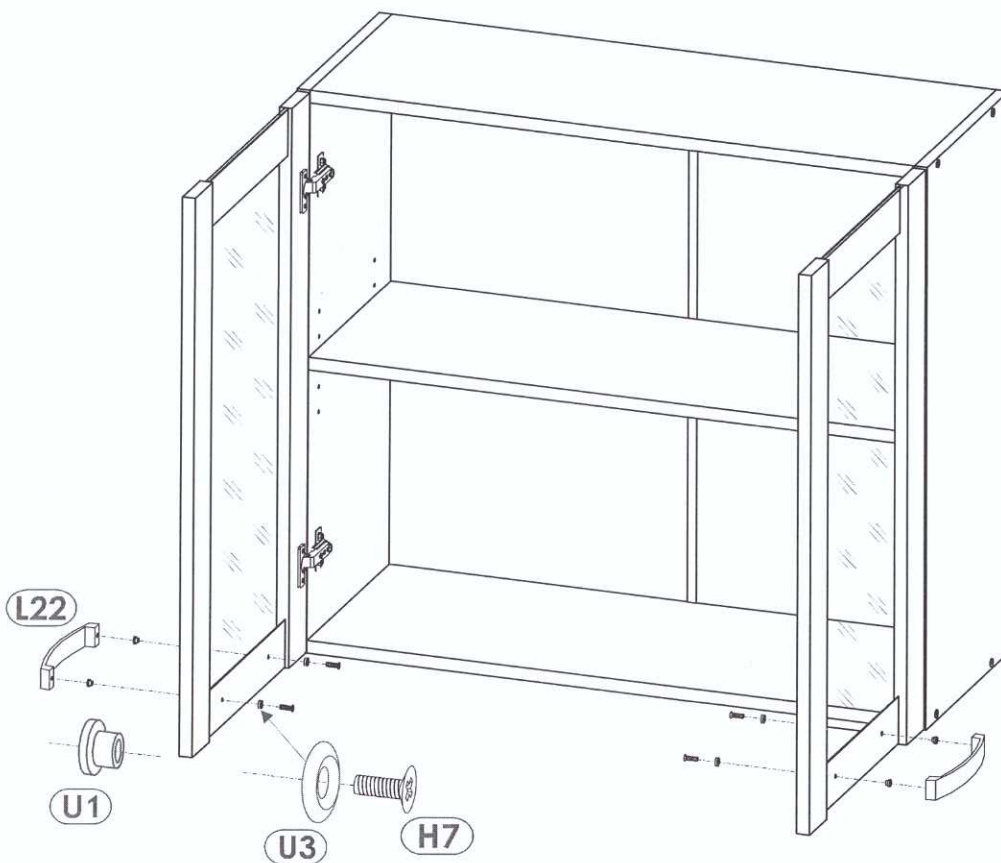

7

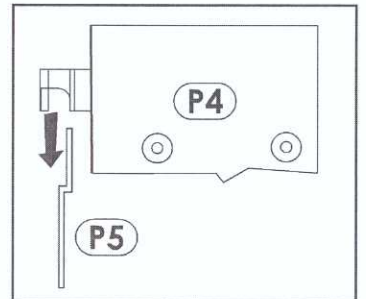
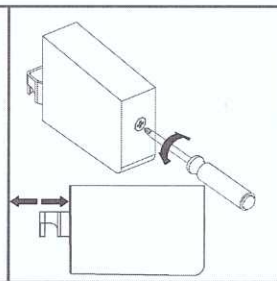
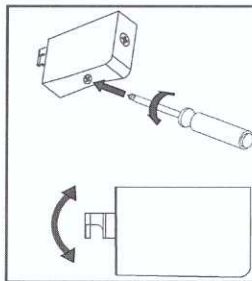
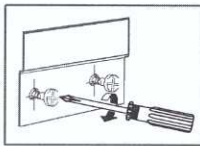
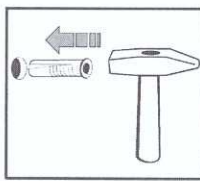
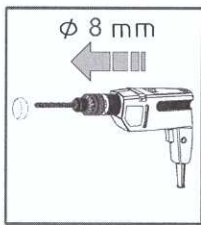
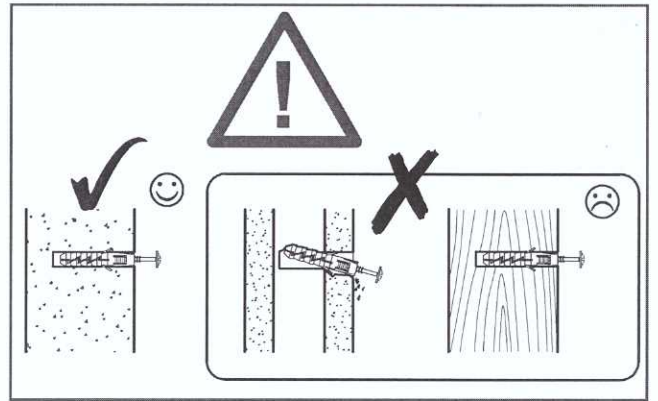
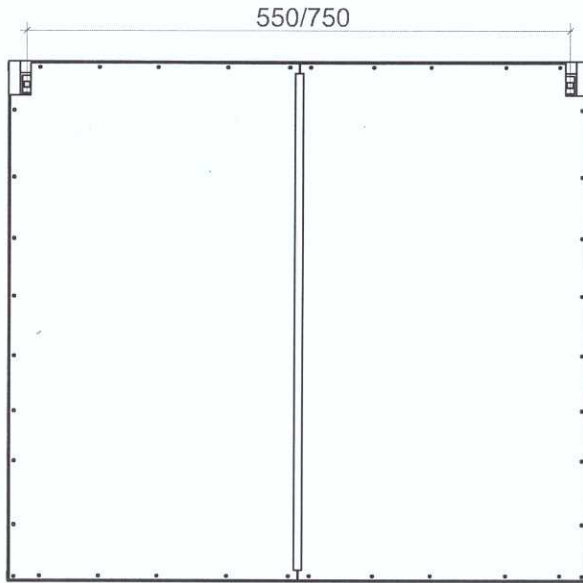

8

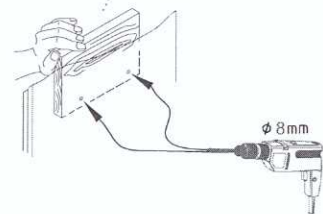
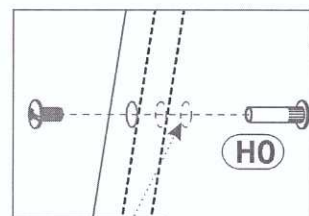
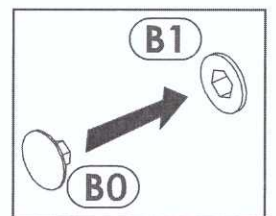
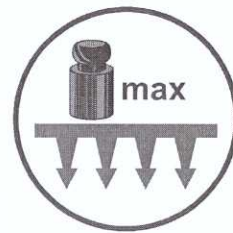
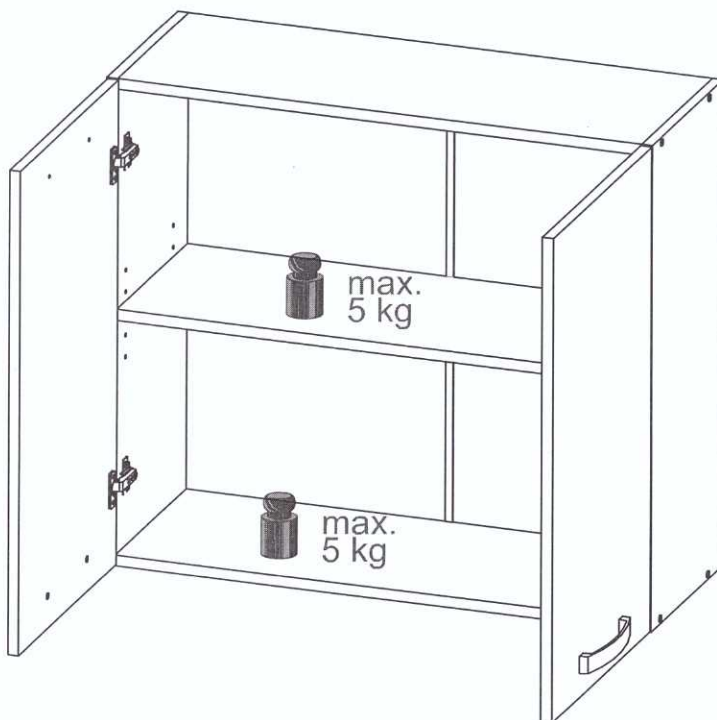

CHARLOTTE 30,40,50 UC 40,50 UDC

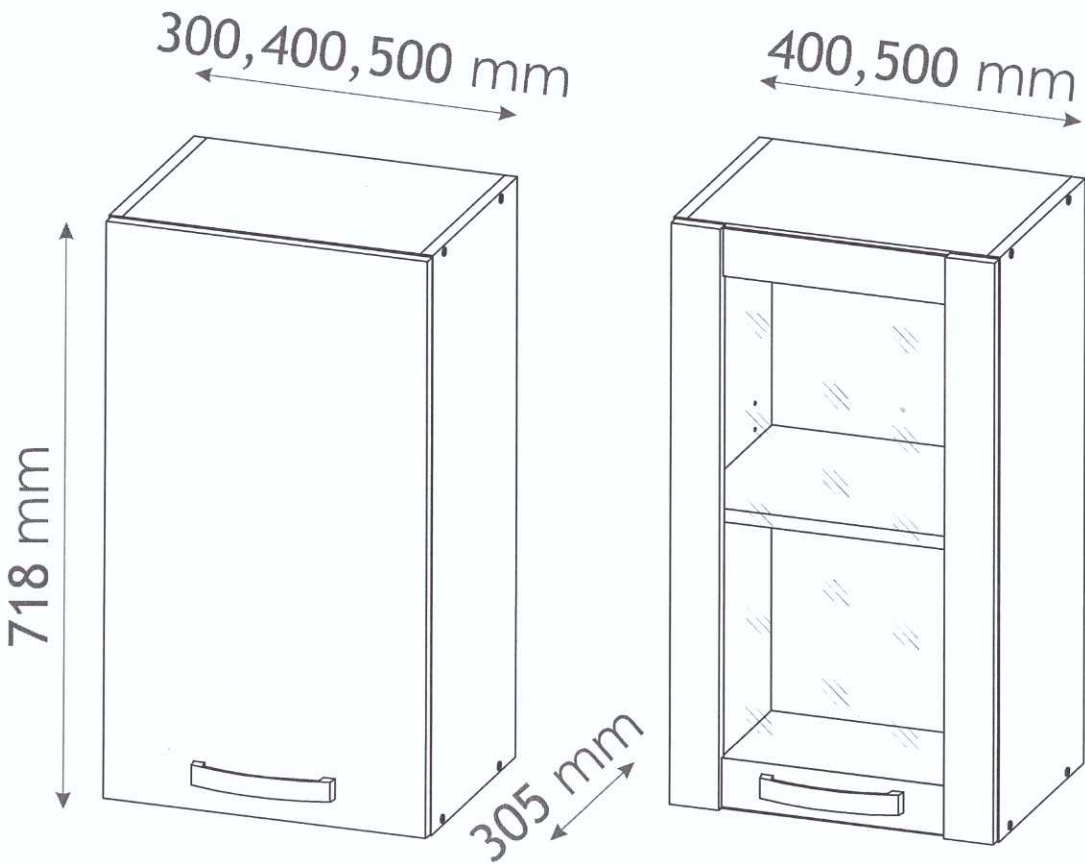
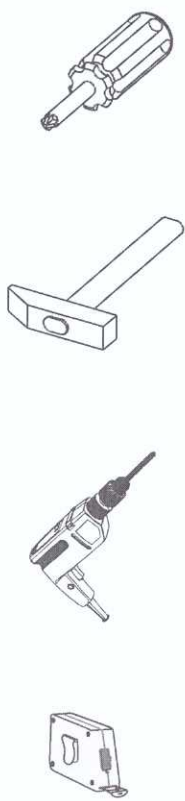
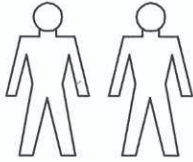





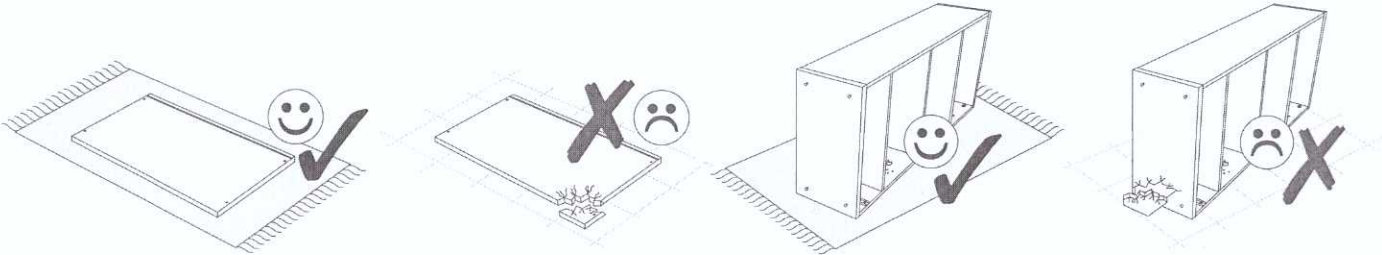







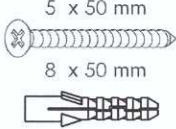

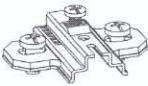
A

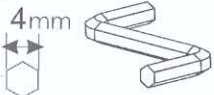
B

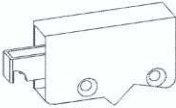

CHARLOTTE 30,40,50 UC 40,50 UDC

| | | |
|--|---|--|
| A0 8 x 32mm x4  | B1 f 7 x 50 mm x8  | B0 x4  |
| D10 4 x 16 mm x4  | D13 4 x 30 mm x4  | E0 5 x 50 mm 8 x 50 mm x4  |
| H0 x2  | J6 x2  | J8 x2  |
| K 4mm x1  | L22 x1  | P4 x2  |
| P5 x2  | Q0 x4  | T8 x25  |

30,40,50 UC

| |
|---|
| H2 4 x 22 mm x2  |
|---|

40,50 UDC

| | |
|---|--|
| H7 4 x 10 mm x2  | U1 x2  |
| U3 x2  | |



CHARLOTTE 30,40,50 UC 40,50 UDC

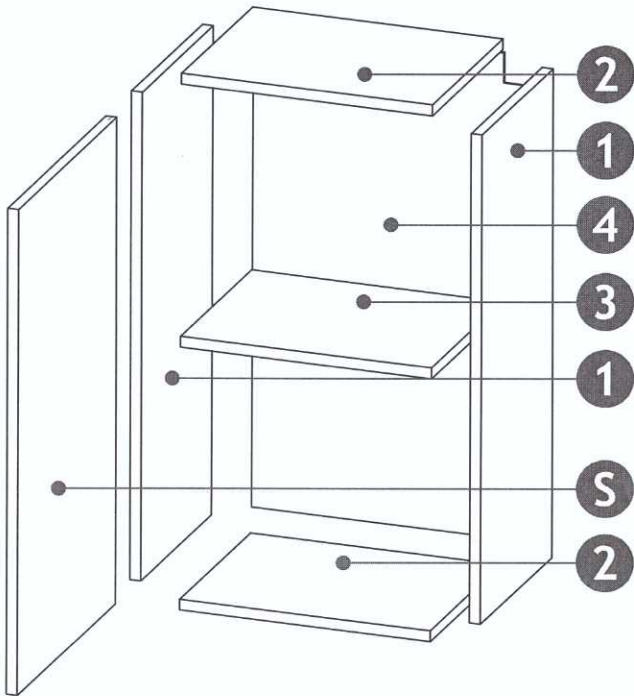

300

| | | | | | |
|---|-----|-----|----|----|-----|
| 1 | 718 | 285 | 16 | x2 | 1/1 |
| 2 | 267 | 285 | 16 | x2 | 1/1 |
| 3 | 266 | 280 | 16 | x1 | 1/1 |
| | | | | | 1/1 |

| | | | | | |
|---|-----|-----|-----|----|-----|
| 4 | 713 | 295 | 2.5 | x1 | 1/1 |
| S | 714 | 297 | 16 | x1 | 1/1 |

400

| | | | | | |
|---|-----|-----|----|----|-----|
| 1 | 718 | 285 | 16 | x2 | 1/1 |
| 2 | 367 | 285 | 16 | x2 | 1/1 |
| 3 | 366 | 280 | 16 | x1 | 1/1 |
| | | | | | 1/1 |

| | | | | | |
|-----|-----|-----|-----|----|-----|
| 4 | 713 | 395 | 2.5 | x1 | 1/1 |
| D S | 714 | 397 | 16 | x1 | 1/1 |

500

| | | | | | |
|---|-----|-----|----|----|-----|
| 1 | 718 | 285 | 16 | x2 | 1/1 |
| 2 | 467 | 285 | 16 | x2 | 1/1 |
| 3 | 466 | 280 | 16 | x1 | 1/1 |
| | | | | | 1/1 |

| | | | | | |
|-----|-----|-----|-----|----|-----|
| 4 | 713 | 495 | 2.5 | x1 | 1/1 |
| D S | 714 | 497 | 16 | x1 | 1/1 |

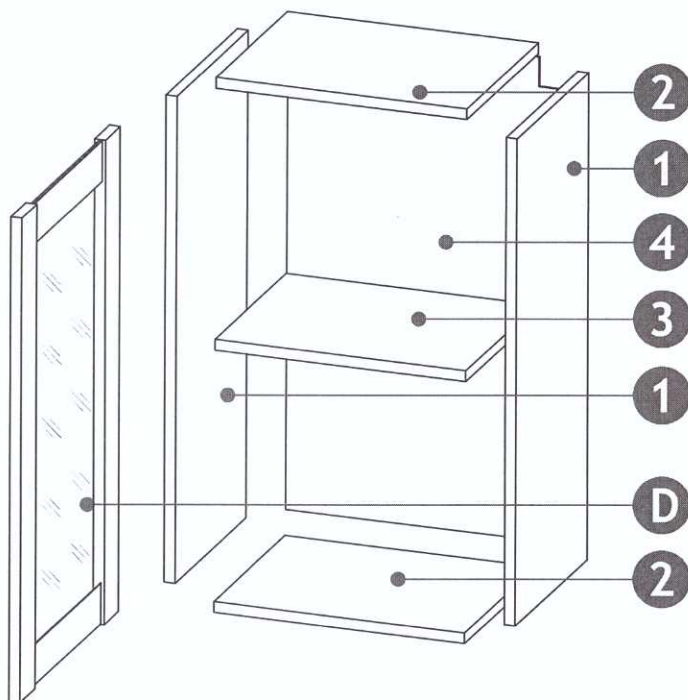

1 ▶

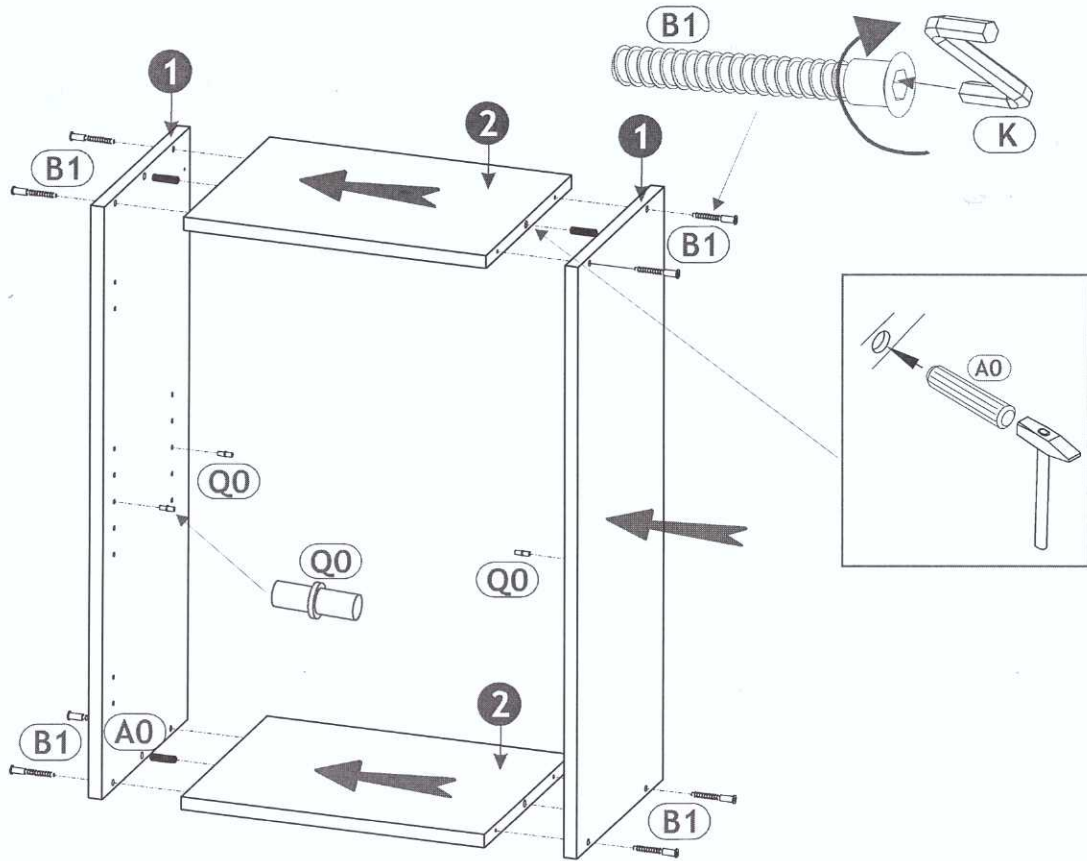

2 ▶

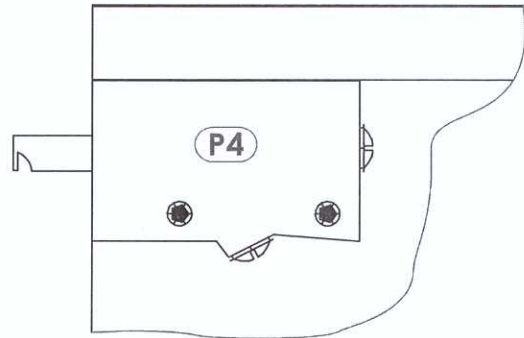
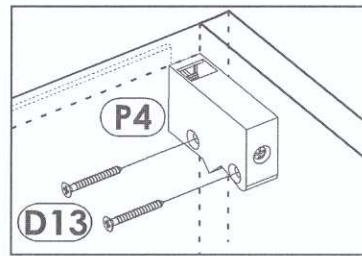
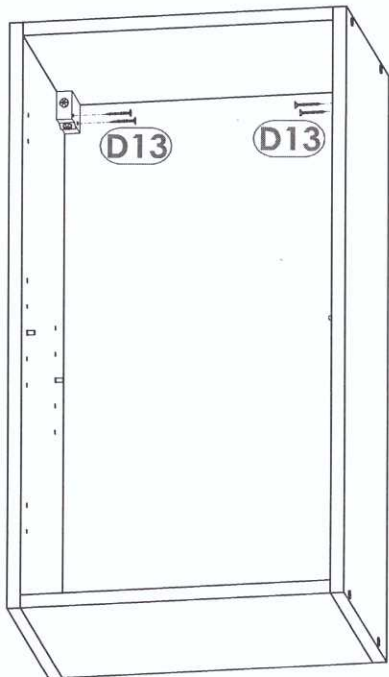

3 ▶

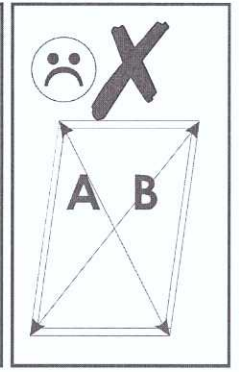
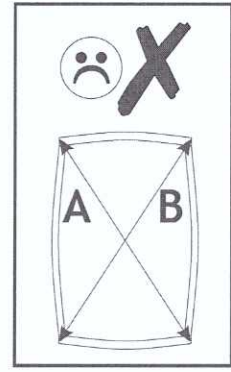
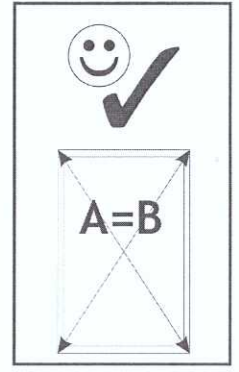
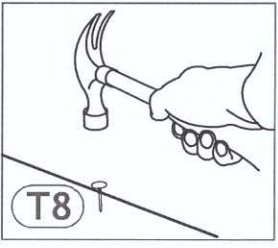
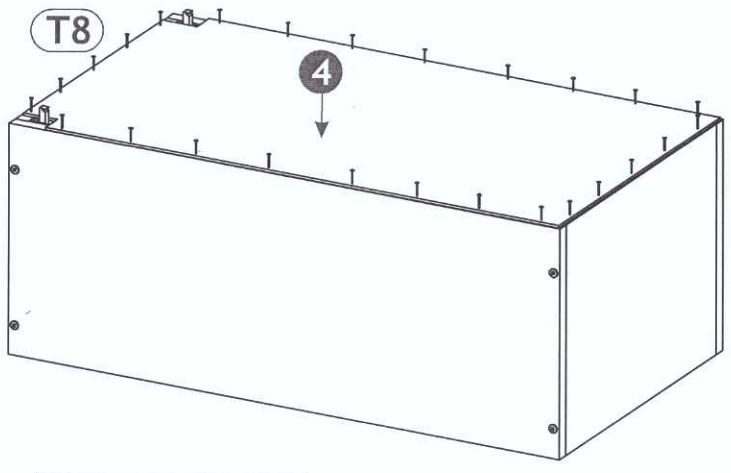

4 ▶ A

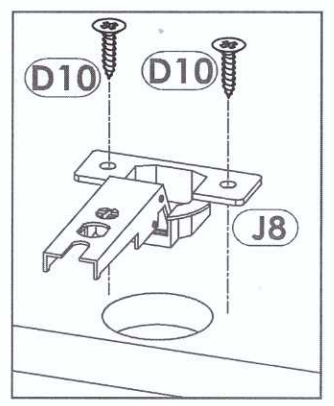
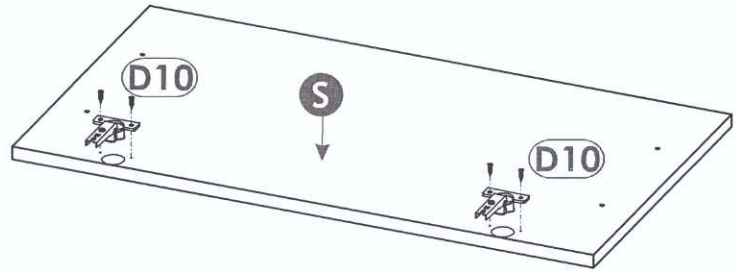

4 ▶ B

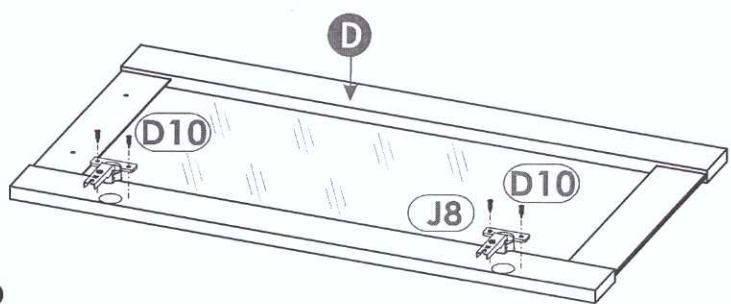

L

4 ▶ B

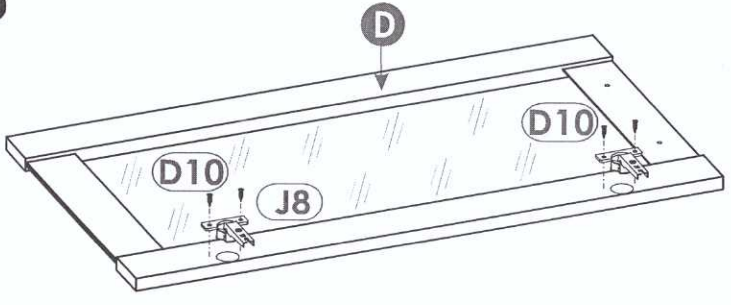

R

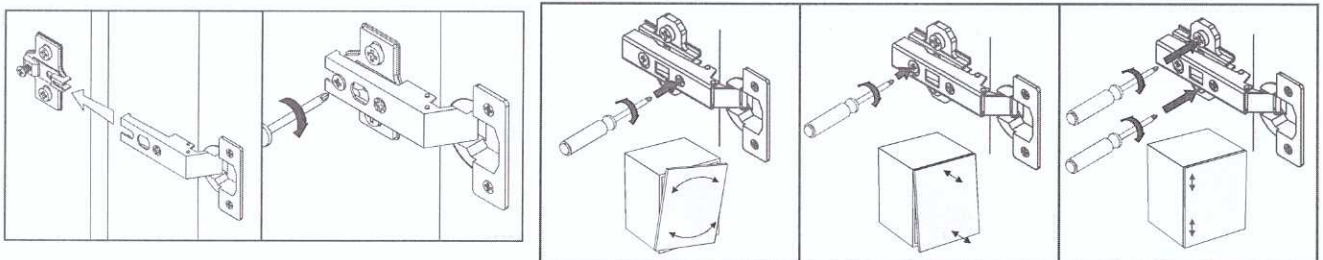
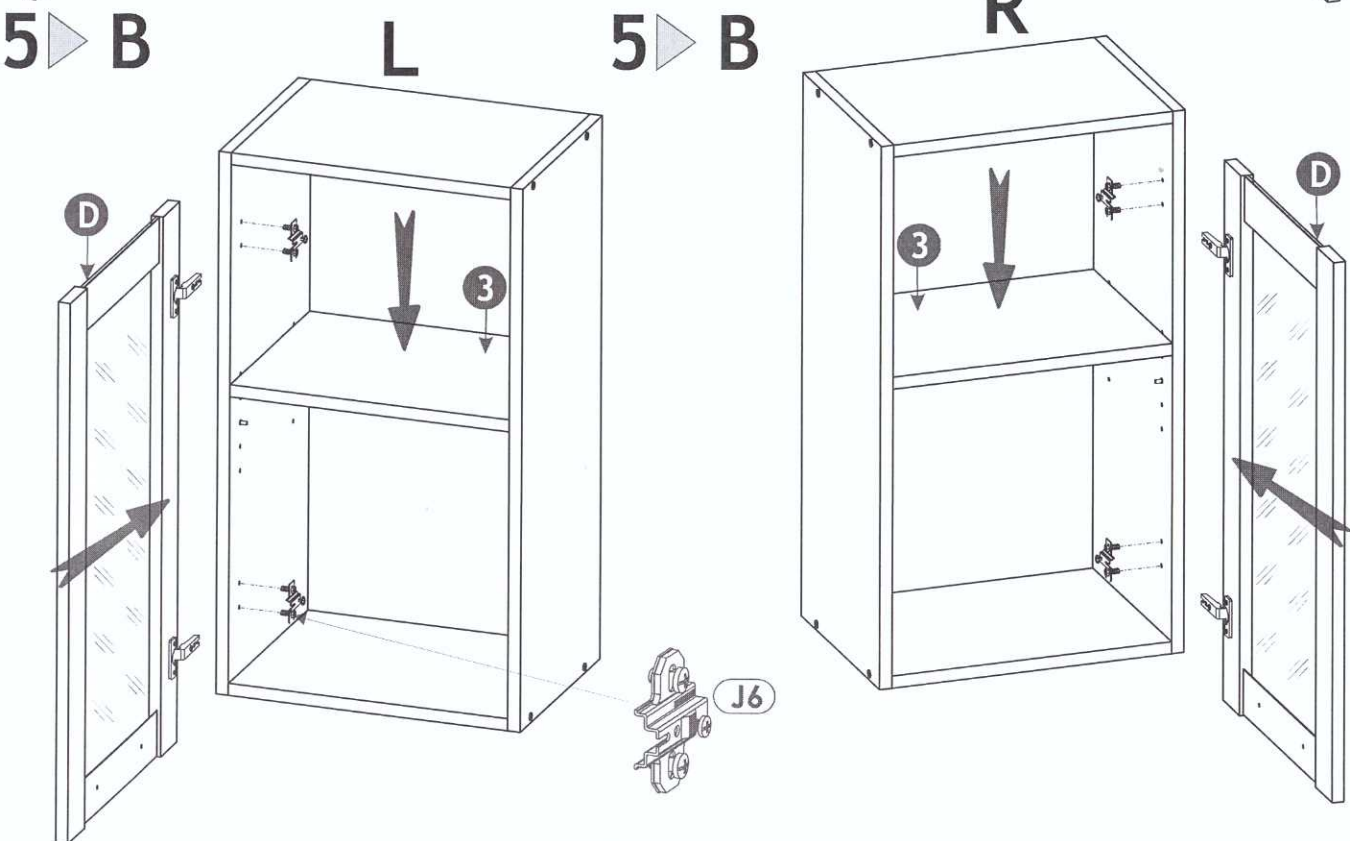
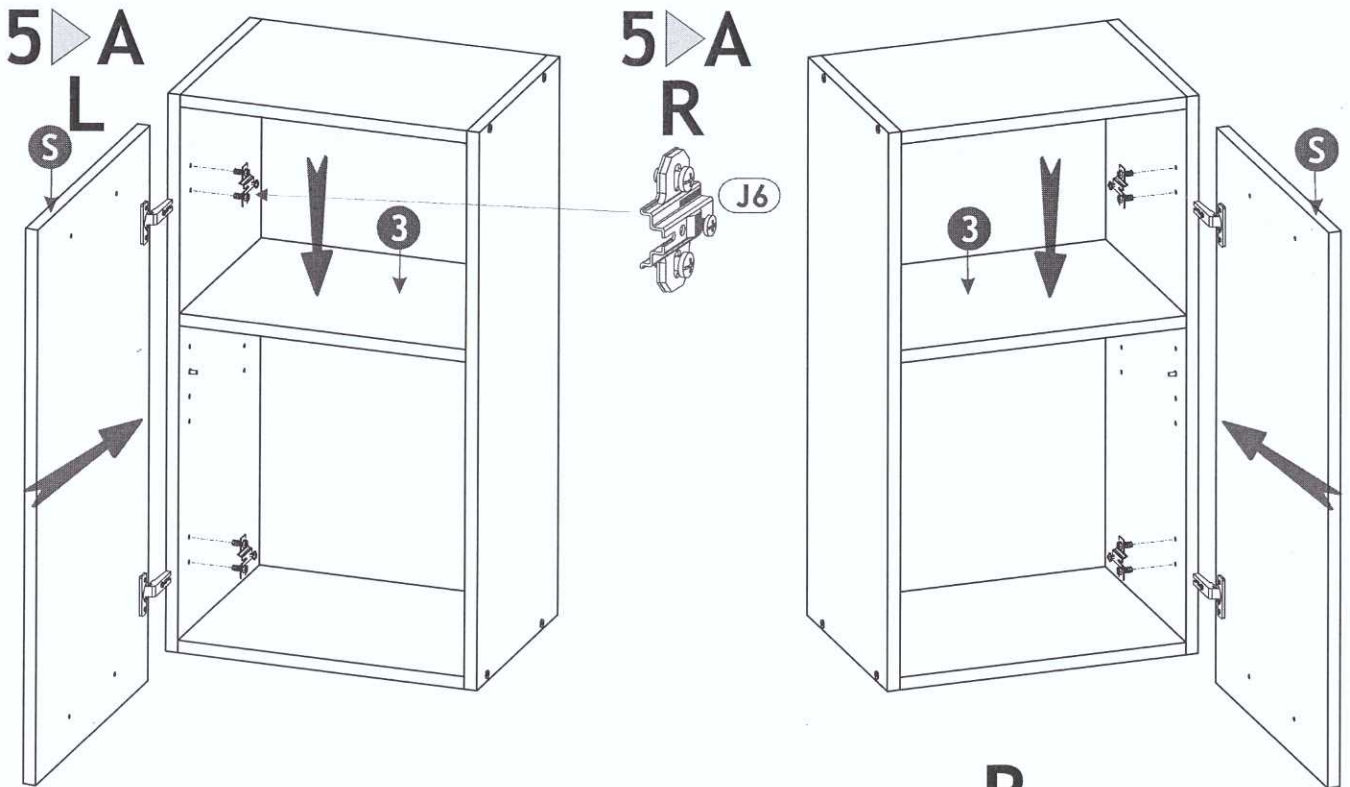

6 ▶ A
L

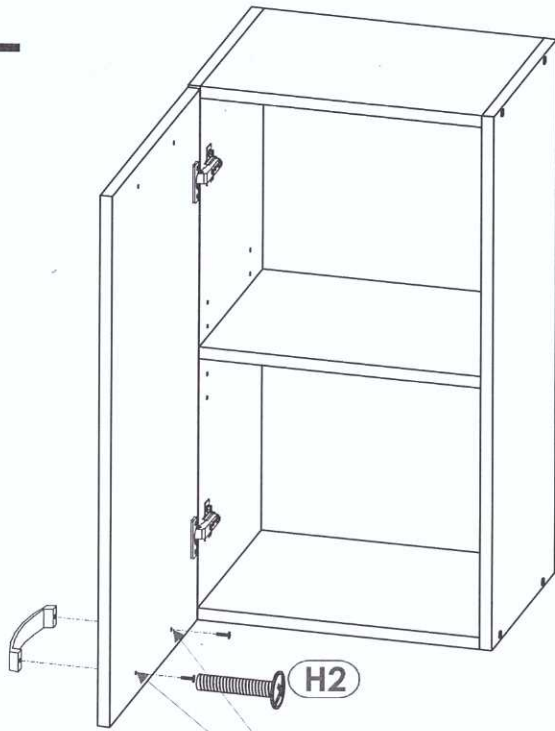

6 ▶ A
R

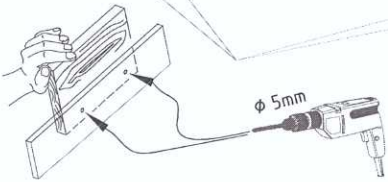
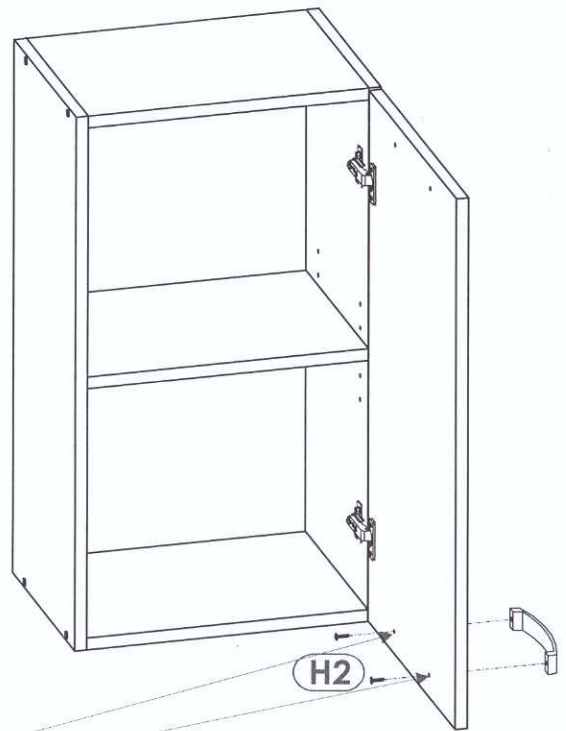

6 ▶ B
L

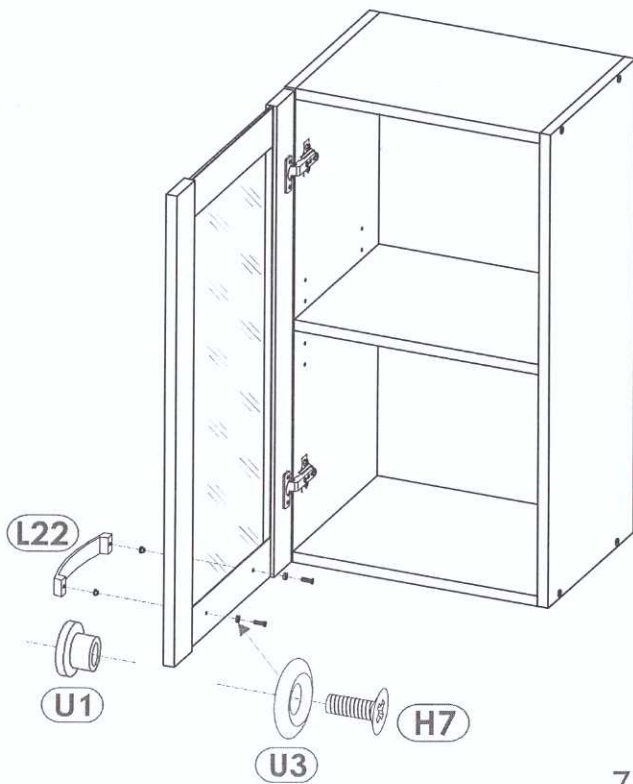

6 ▶ B
R

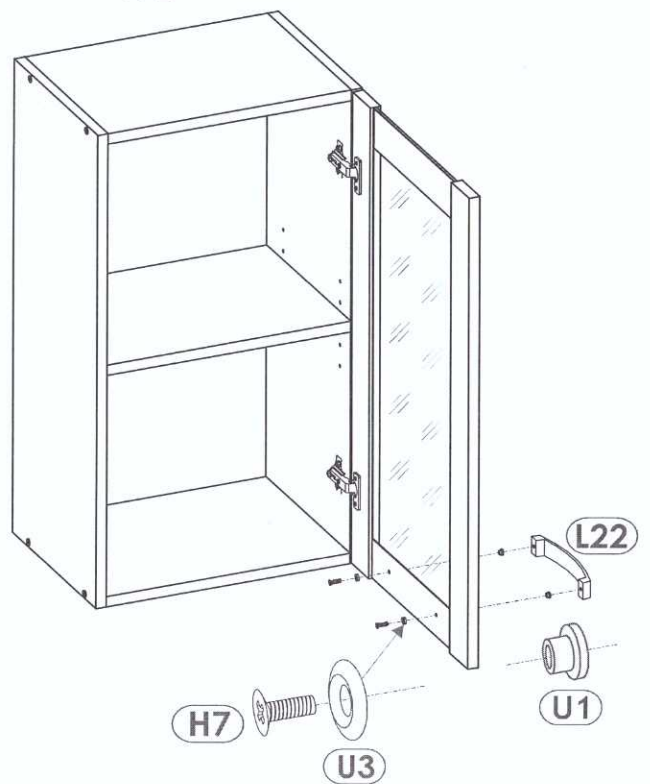

7 ▶

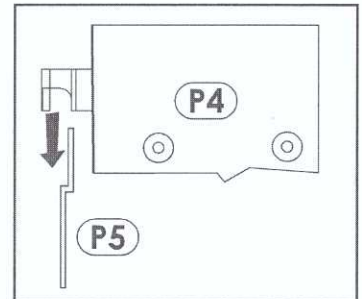
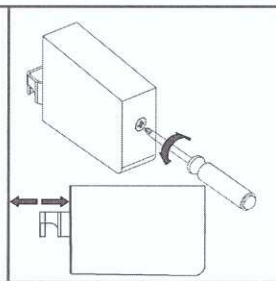
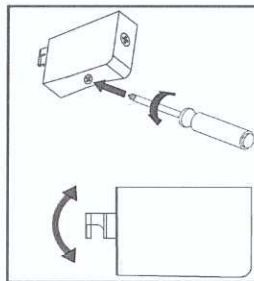
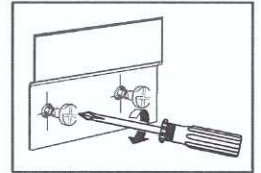
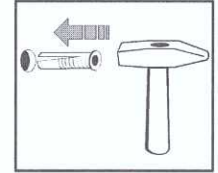
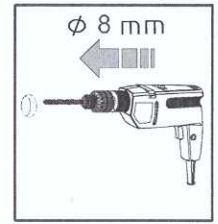
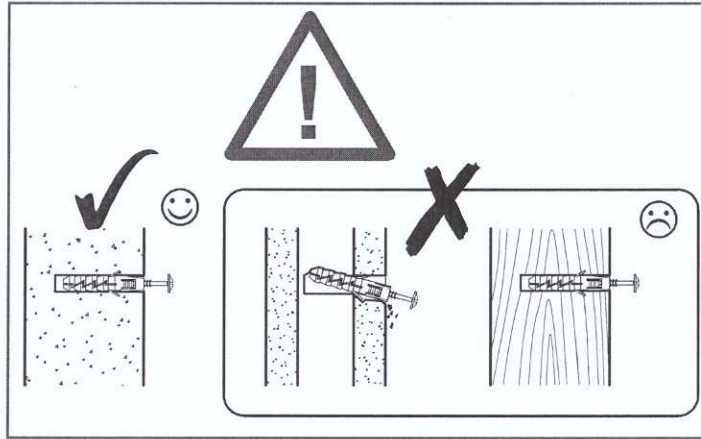
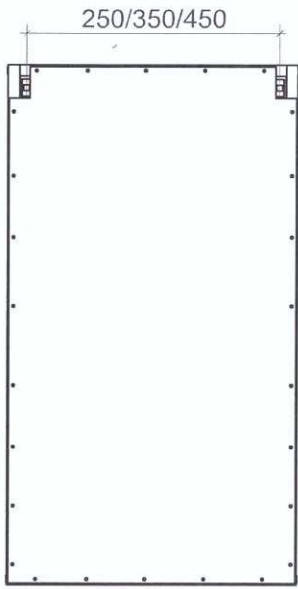



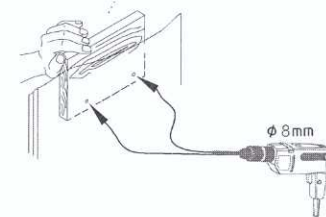
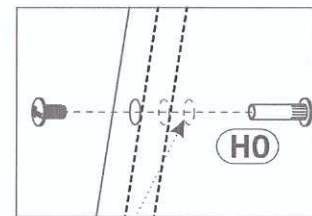
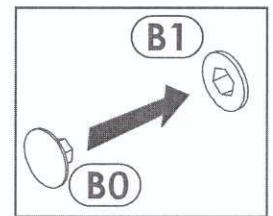
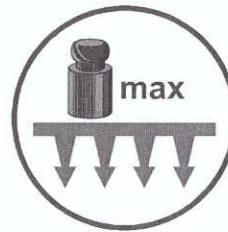
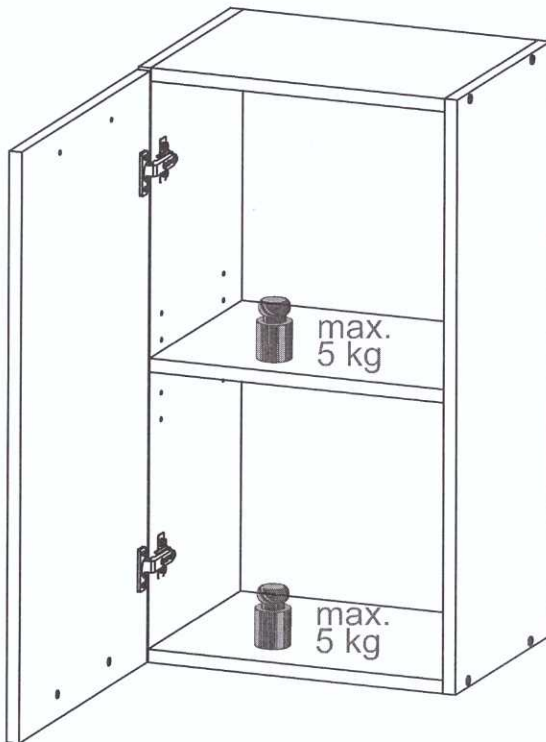



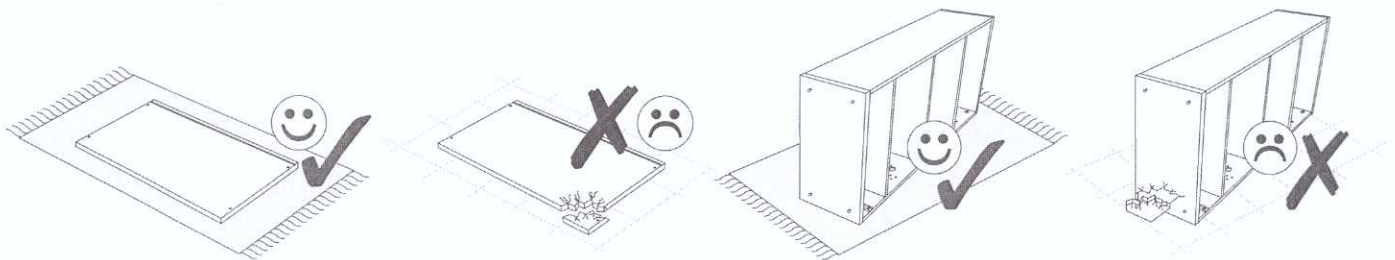
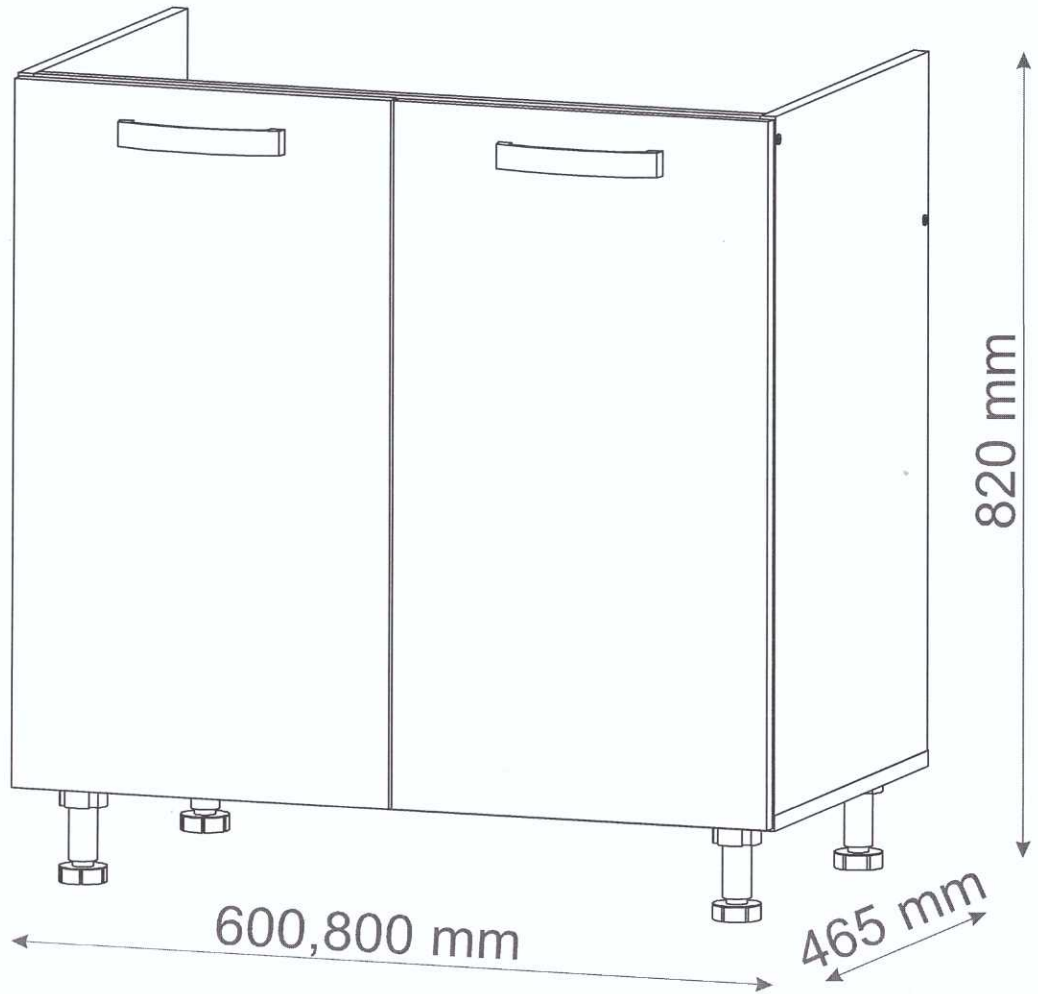
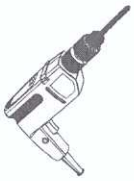
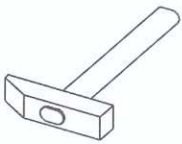
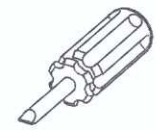
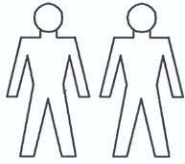



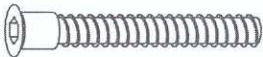

8 ▶

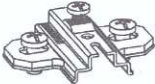

CHARLOTTE 60, 80LC for the kitchen sink



CHARLOTTE 60, 80LC for the kitchen sink

| | | |
|--|---|---|
| A0 8 x 32mm x4  | B1 f 7 x 50 mm x10  | B0 x2  |
| D10 4 x 16 mm x28  | D14 4 x 35 mm x2  | H0 x2  |
| H2 4 x 22 mm x4  | J6 x4  | J8 x4  |
| K x1  | L22 x2  | T8 x20  |
| T14 x4  | T15 x2  | |

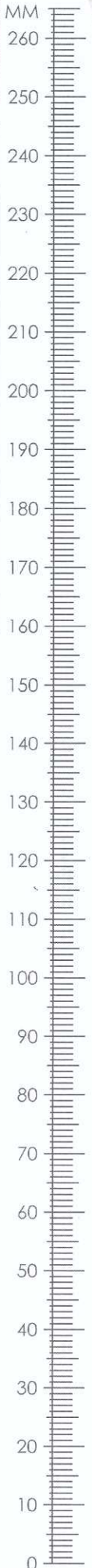

CHARLOTTE 60, 80LC for the kitchen sink

600

| | | | | | |
|---|-----|-----|-----|----|-----|
| 1 | 704 | 445 | 16 | x1 | 1/1 |
| 2 | 567 | 80 | 16 | x1 | 1/1 |
| 3 | 567 | 80 | 16 | x1 | 1/1 |
| 4 | 704 | 445 | 16 | x1 | 1/1 |
| 5 | 600 | 445 | 16 | x1 | 1/1 |
| 6 | 250 | 250 | 2,5 | x2 | 1/1 |
|  | | | | | 1/1 |

| | | | | | |
|----------|-----|-----|----|----|-----|
| 7 | 714 | 297 | 16 | x2 | 1/1 |
|----------|-----|-----|----|----|-----|

800

| | | | | | |
|--|-----|-----|-----|----|-----|
| 1 | 704 | 445 | 16 | x1 | 1/1 |
| 2 | 767 | 80 | 16 | x1 | 1/1 |
| 3 | 767 | 80 | 16 | x1 | 1/1 |
| 4 | 704 | 445 | 16 | x1 | 1/1 |
| 5 | 800 | 445 | 16 | x1 | 1/1 |
| 6 | 250 | 250 | 2,5 | x2 | 1/1 |
|  | | | | | 1/1 |

| | | | | | |
|----------|-----|-----|----|----|-----|
| 7 | 714 | 397 | 16 | x2 | 1/1 |
|----------|-----|-----|----|----|-----|

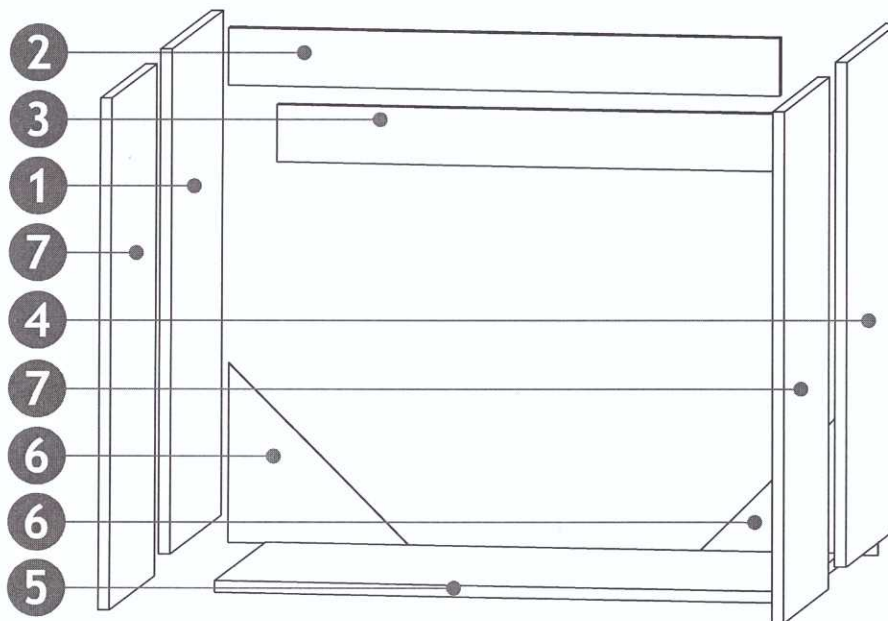

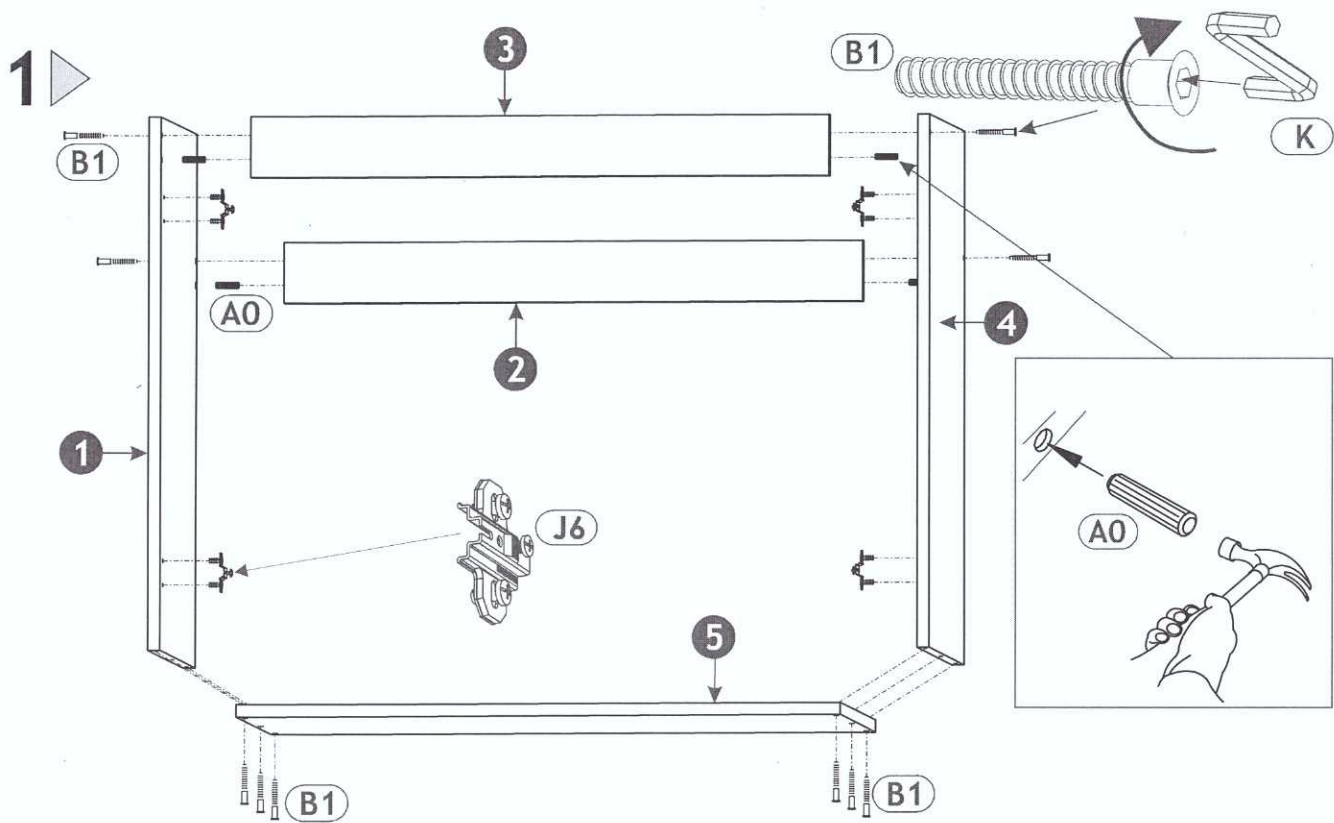

2

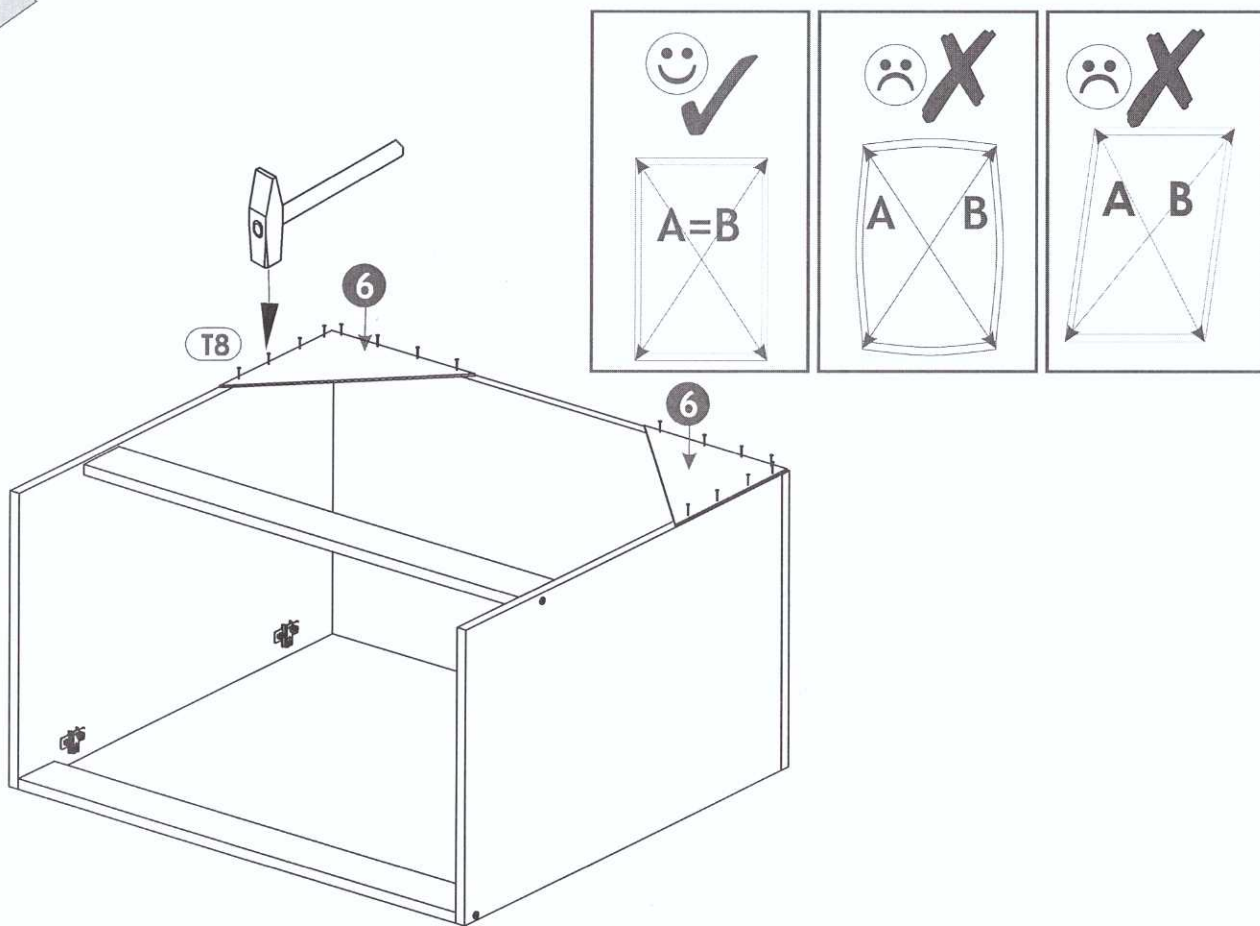

3 ▶

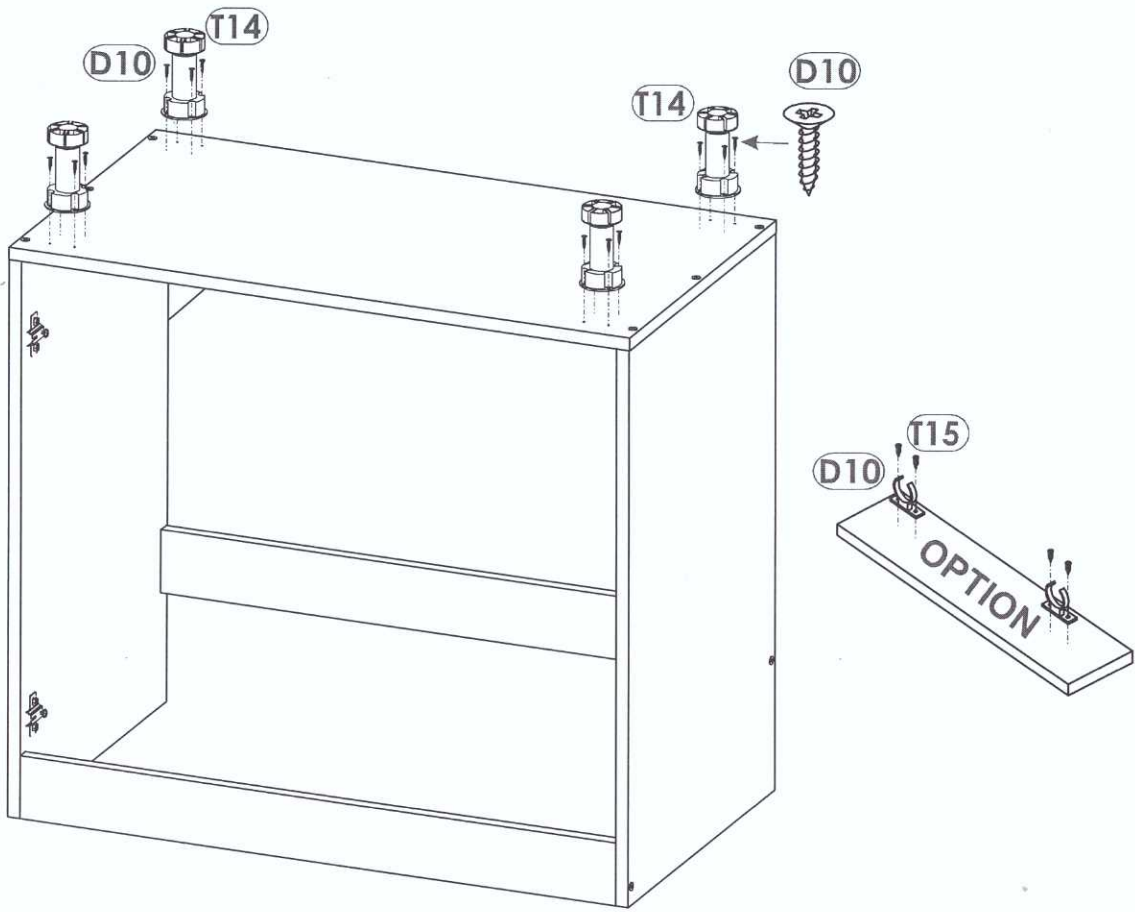

4 ▶

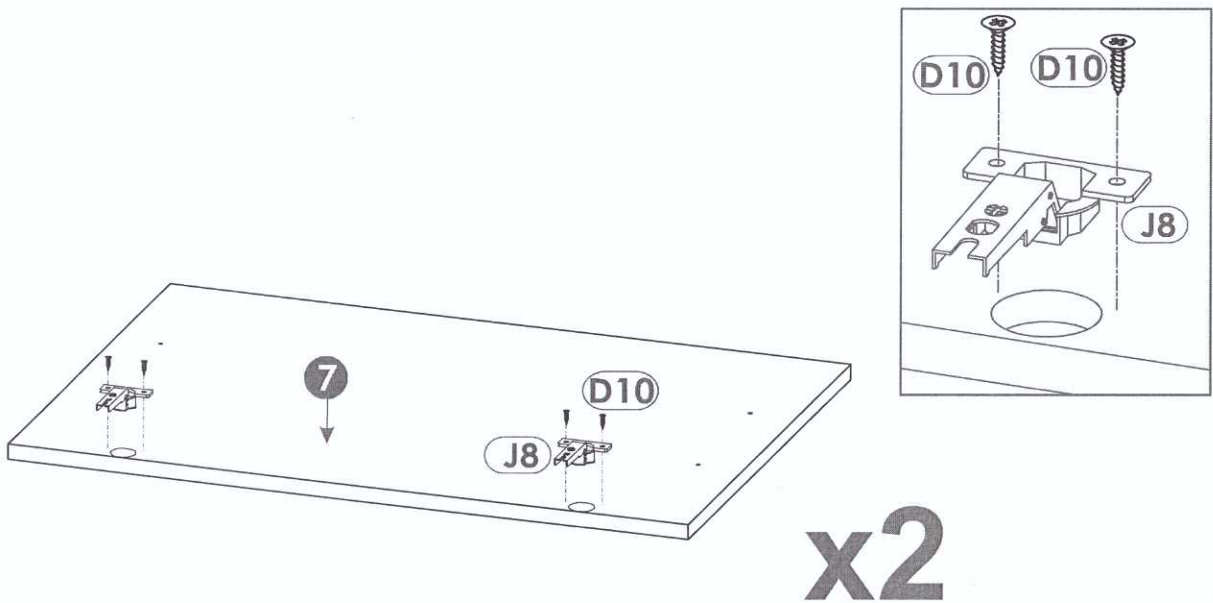

5 ▶

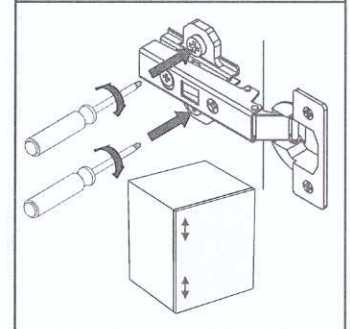
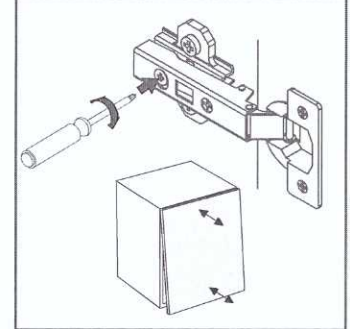
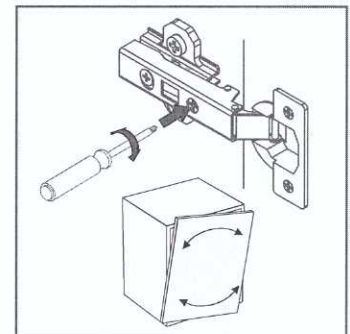
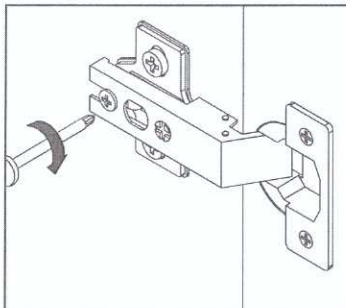
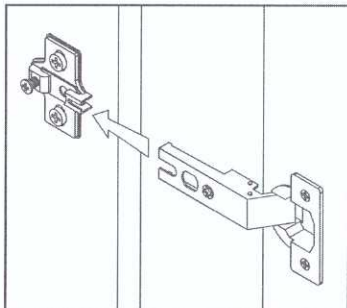
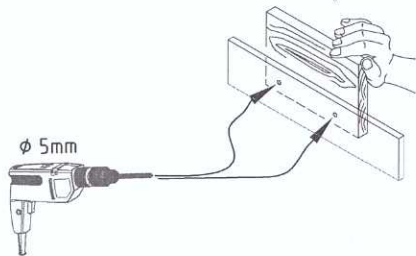
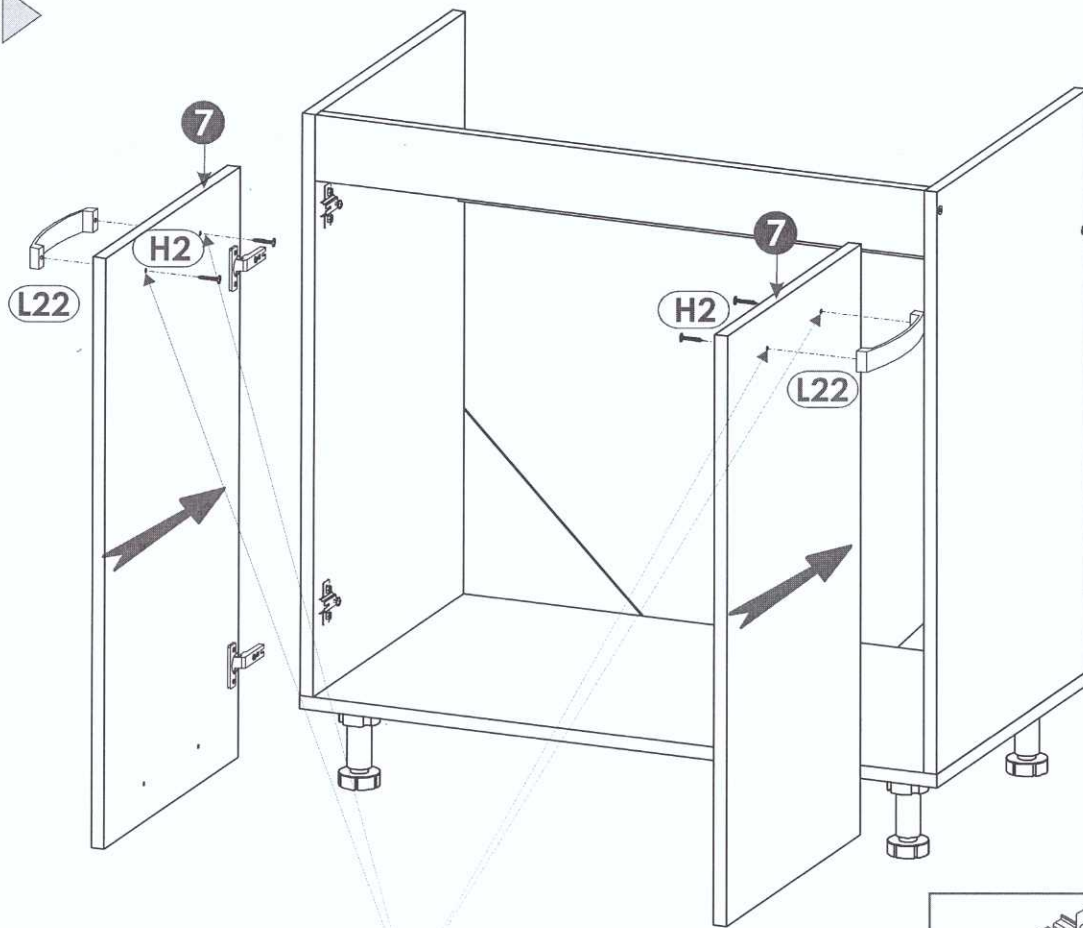



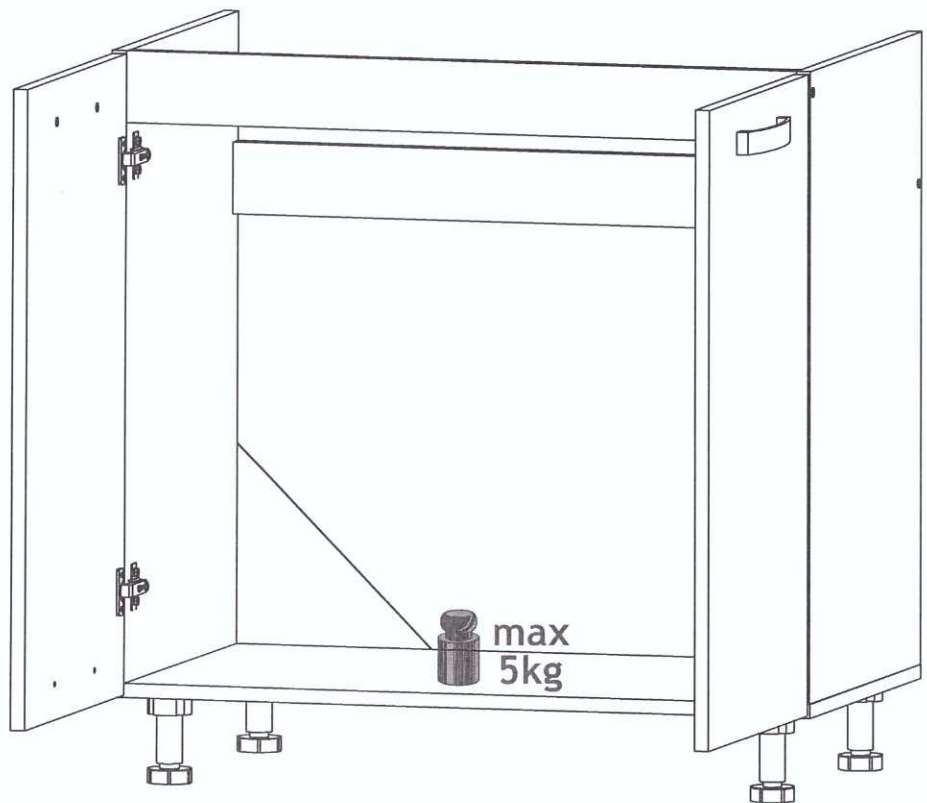
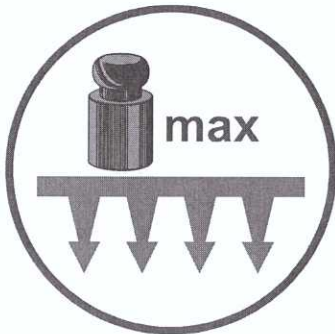
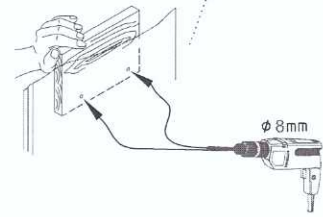
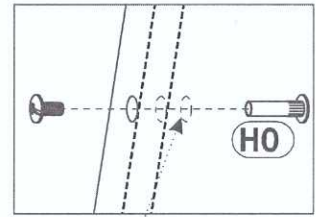
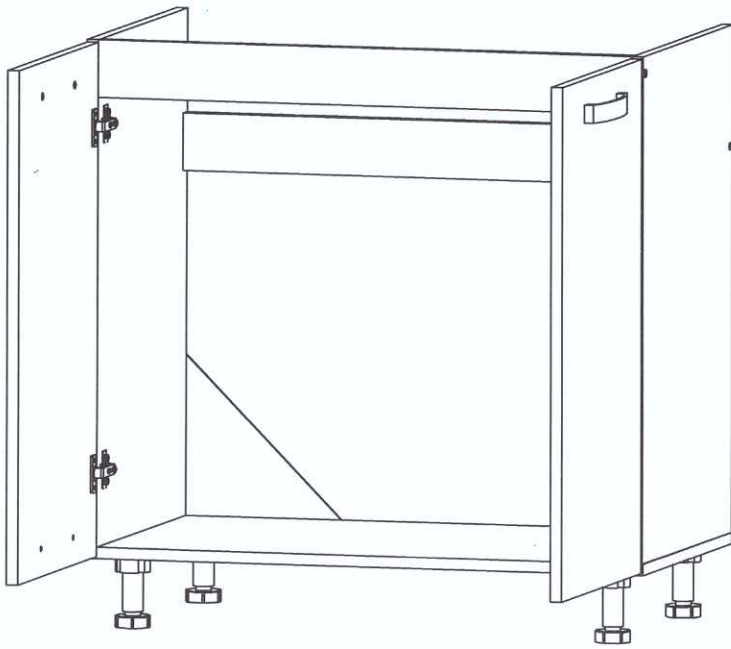



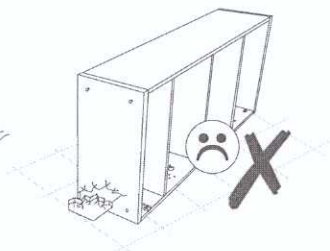
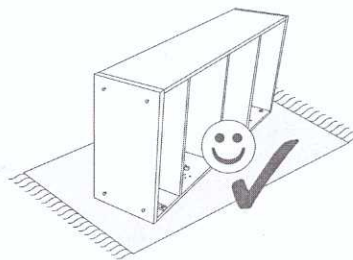
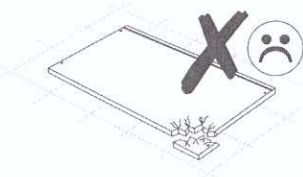
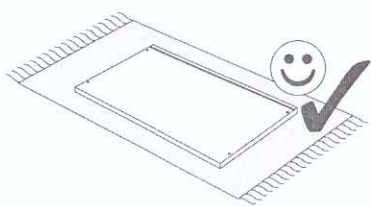
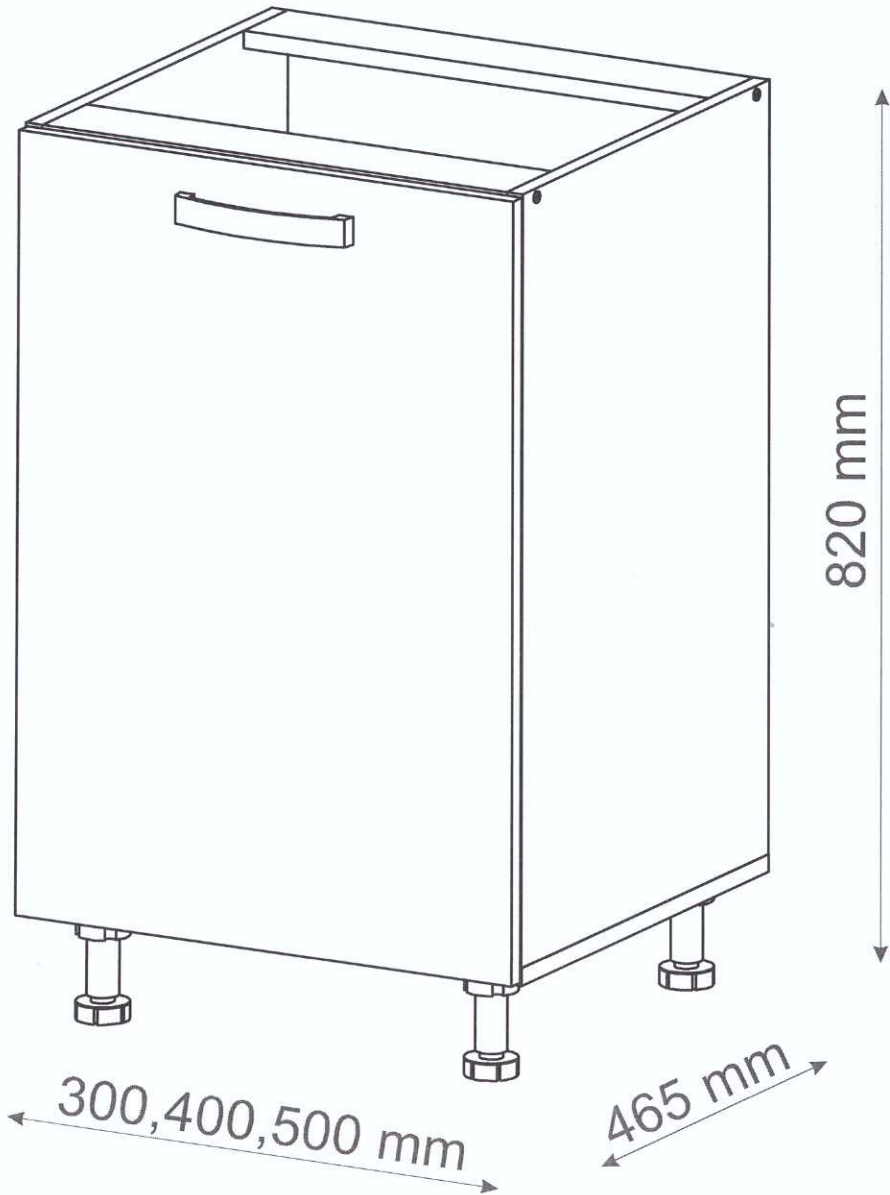
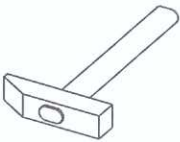
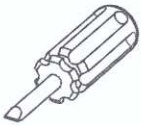
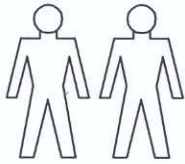
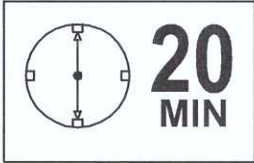



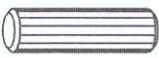

6 ▶



CHARLOTTE 30 LC , 40 LC , 50 LC

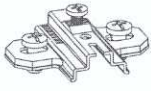
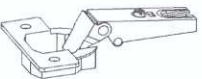

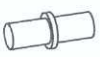
CHARLOTTE 30 LC, 40 LC, 50 LC

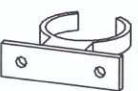
| | | |
|--|---|---|
| A0 8 x 32mm x4  | B1 f 7 x 50 mm x10  | B0  x2 |
| D2 3 x 30 mm x4  | D10 4 x 16 mm x24  | D14 4 x 35 mm x2  |
| H0  x2 | H2 4 x 22 mm x2  | J6  x2 |
| J8  x2 | K 4mm  x1 | L22  x1 |
| Q0  x4 | T8  x40 | T14  x4 |
| T15  x2 | | |

50 LC

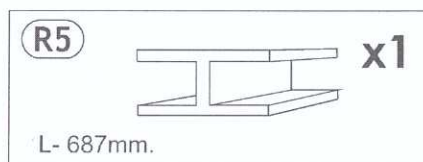

CHARLOTTE 30 LC , 40 LC , 50 LC

30 LC, 40 LC

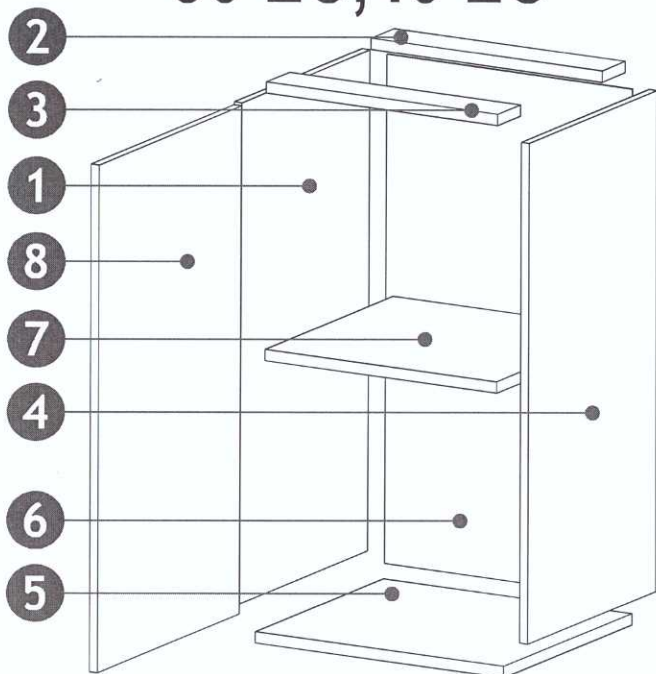

300

| | | | | | |
|---|-----|-----|-----|----|-----|
| 1 | 704 | 445 | 16 | x1 | 1/1 |
| 2 | 267 | 80 | 16 | x1 | 1/1 |
| 3 | 267 | 80 | 16 | x1 | 1/1 |
| 4 | 704 | 445 | 16 | x1 | 1/1 |
| 5 | 300 | 445 | 16 | x1 | 1/1 |
| 6 | 715 | 295 | 2,5 | x1 | 1/1 |
| 7 | 266 | 440 | 16 | x1 | 1/1 |
| | | | | | 1/1 |
| 8 | 297 | 714 | 16 | x1 | 1/1 |

400

| | | | | | |
|---|-----|-----|-----|----|-----|
| 1 | 704 | 445 | 16 | x1 | 1/1 |
| 2 | 367 | 80 | 16 | x1 | 1/1 |
| 3 | 367 | 80 | 16 | x1 | 1/1 |
| 4 | 704 | 445 | 16 | x1 | 1/1 |
| 5 | 400 | 445 | 16 | x1 | 1/1 |
| 6 | 715 | 395 | 2,5 | x1 | 1/1 |
| 7 | 366 | 440 | 16 | x1 | 1/1 |
| | | | | | 1/1 |
| 8 | 397 | 714 | 16 | x1 | 1/1 |

50 LC

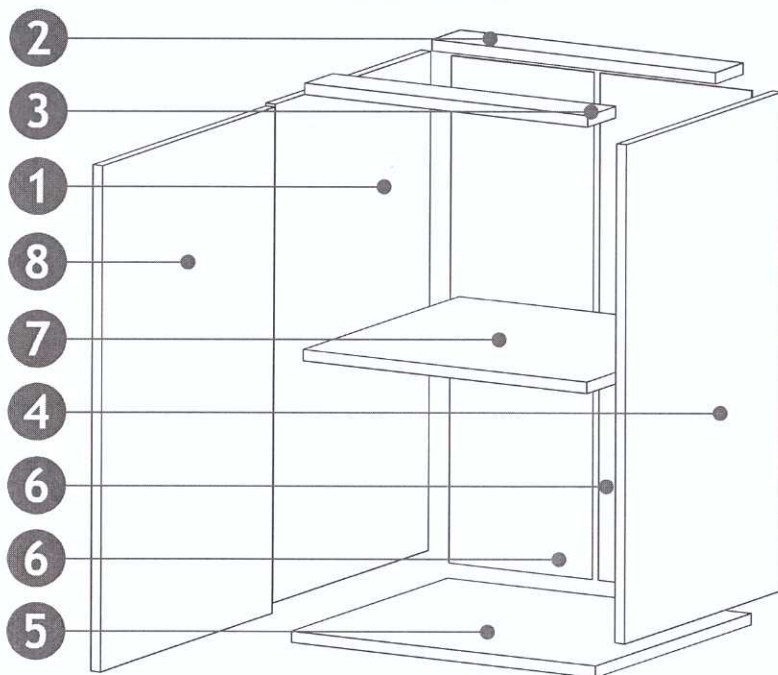

500

| | | | | | |
|---|-----|-----|-----|----|-----|
| 1 | 704 | 445 | 16 | x1 | 1/1 |
| 2 | 467 | 80 | 16 | x1 | 1/1 |
| 3 | 467 | 80 | 16 | x1 | 1/1 |
| 4 | 704 | 445 | 16 | x1 | 1/1 |
| 5 | 500 | 445 | 16 | x1 | 1/1 |
| 6 | 715 | 247 | 2,5 | x2 | 1/1 |
| 7 | 466 | 440 | 16 | x1 | 1/1 |
| | | | | | 1/1 |
| 8 | 497 | 714 | 16 | x1 | 1/1 |

1 ▶

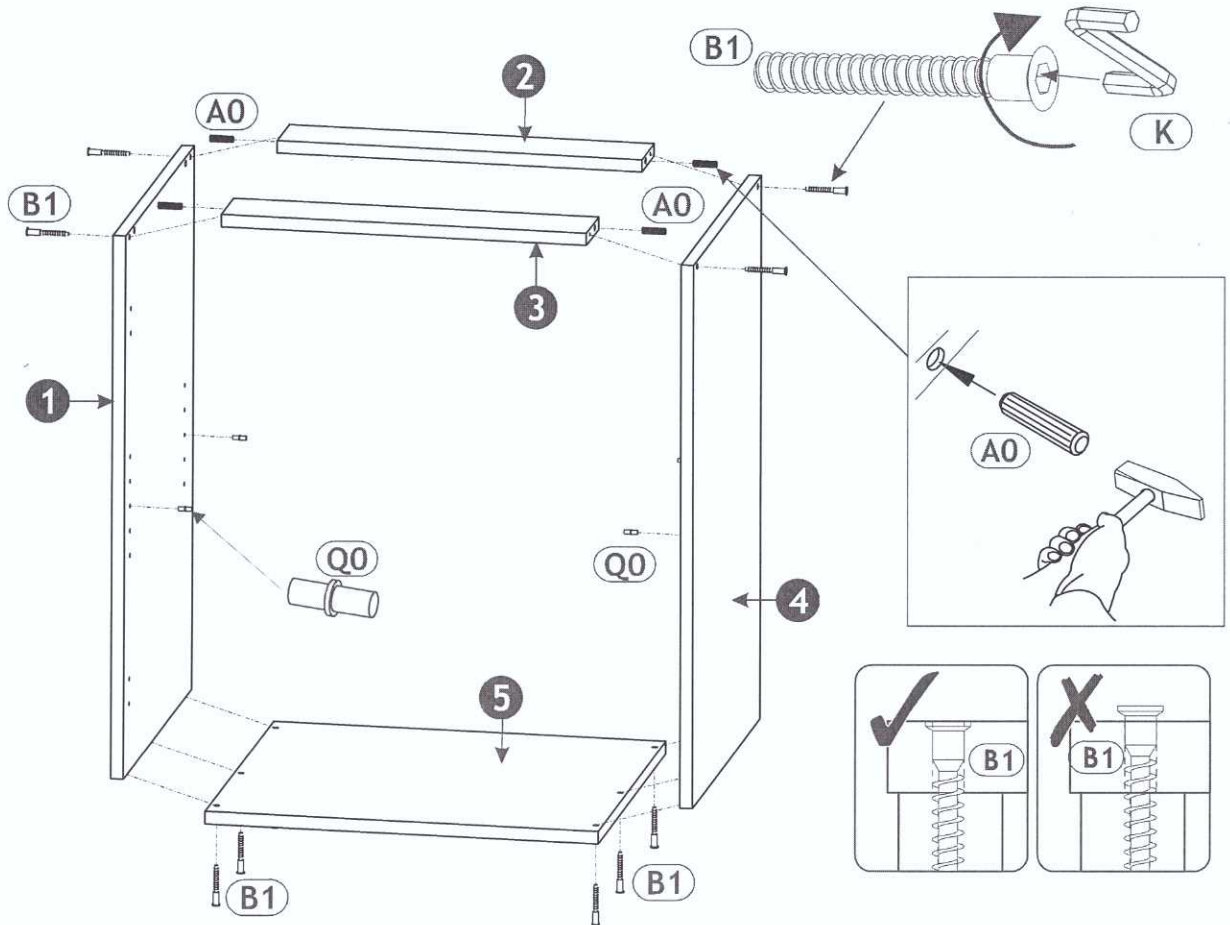

2 ▶

30 LC, 40 LC

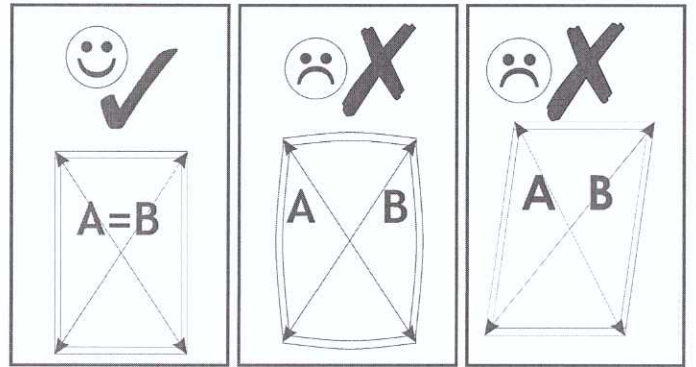
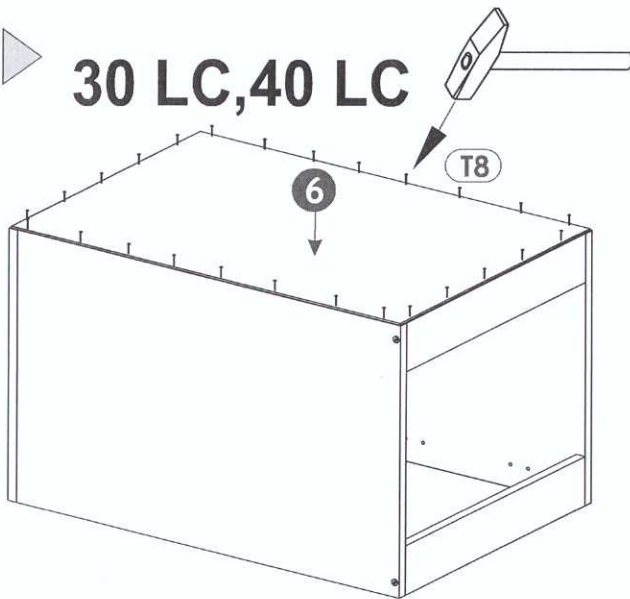

50 LC

R5



3 ▶

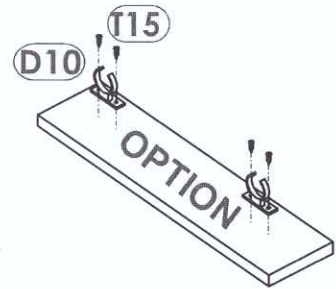
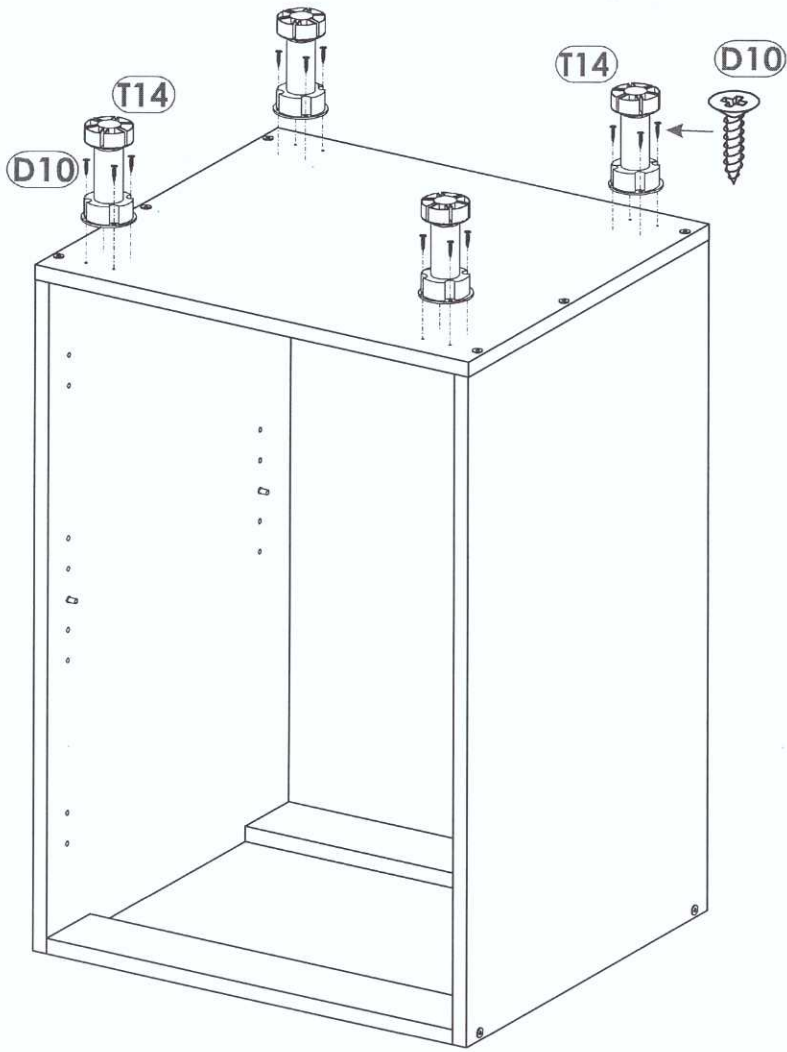

4 ▶

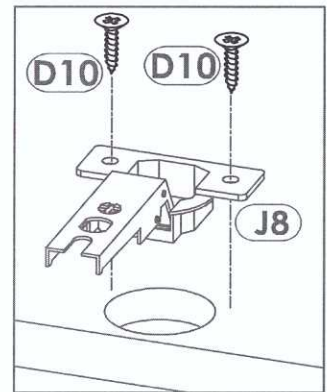
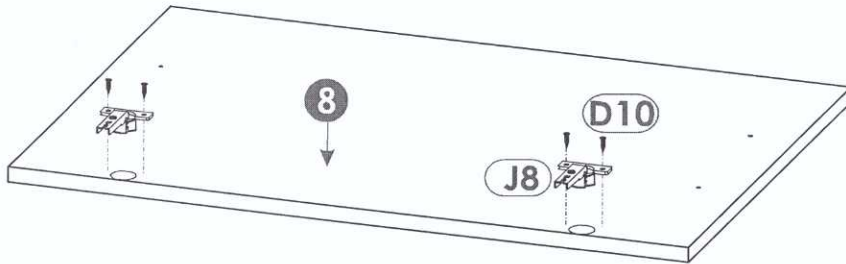

5 ▶ L

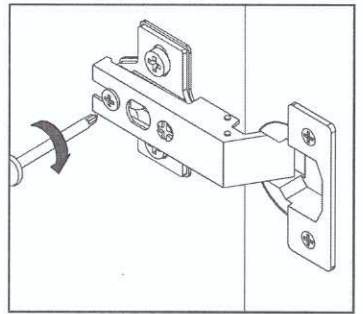
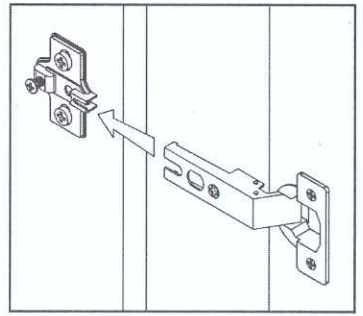
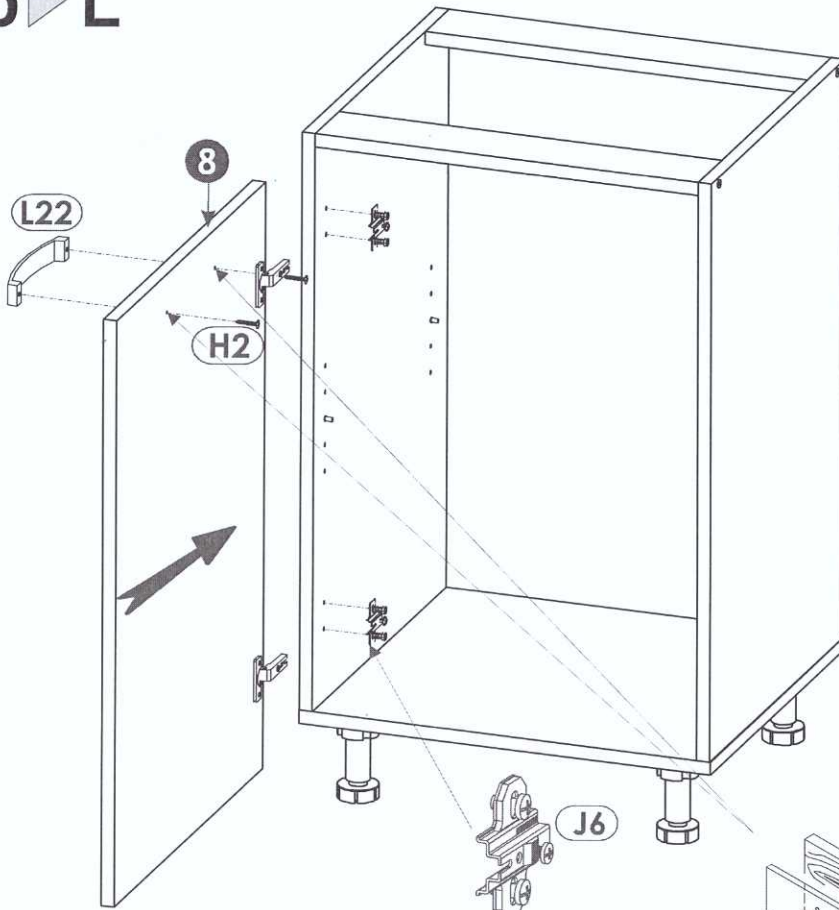

5 ▶ R

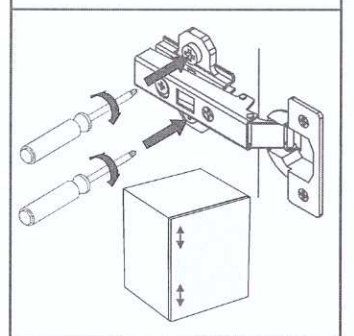
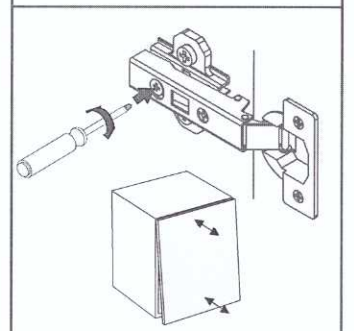
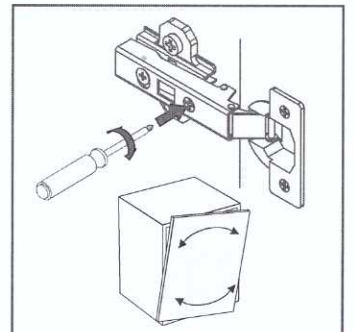
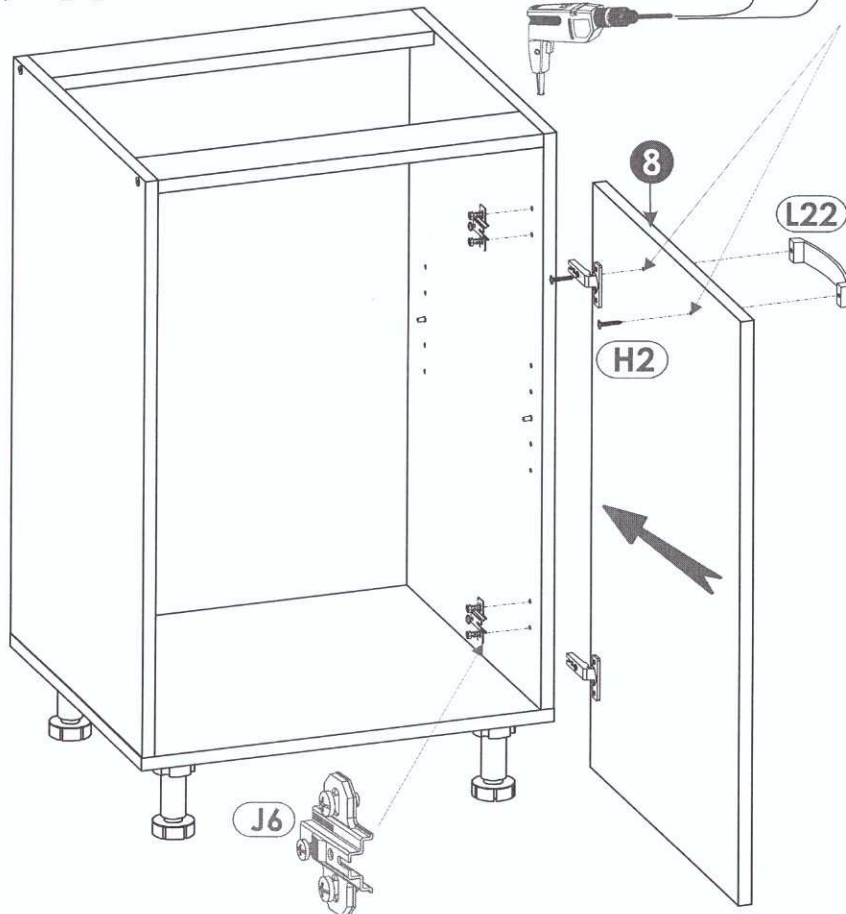

6 ▶

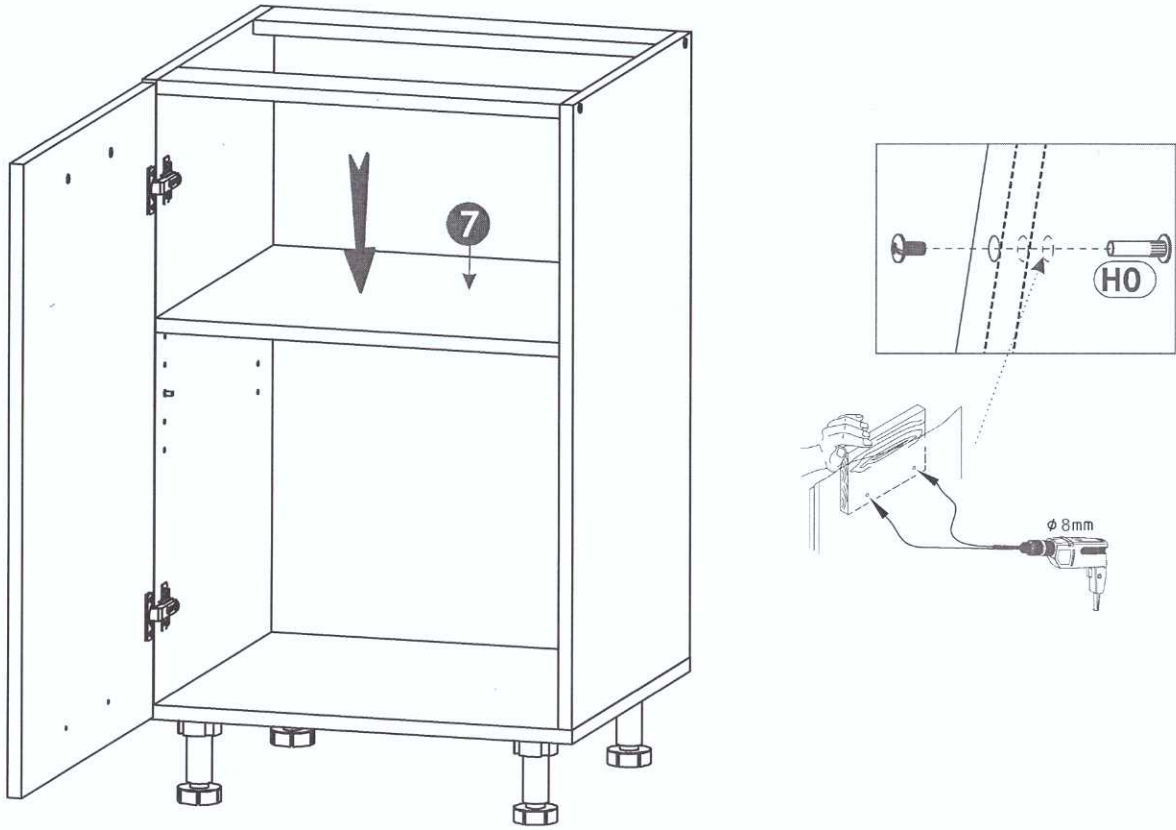

7 ▶

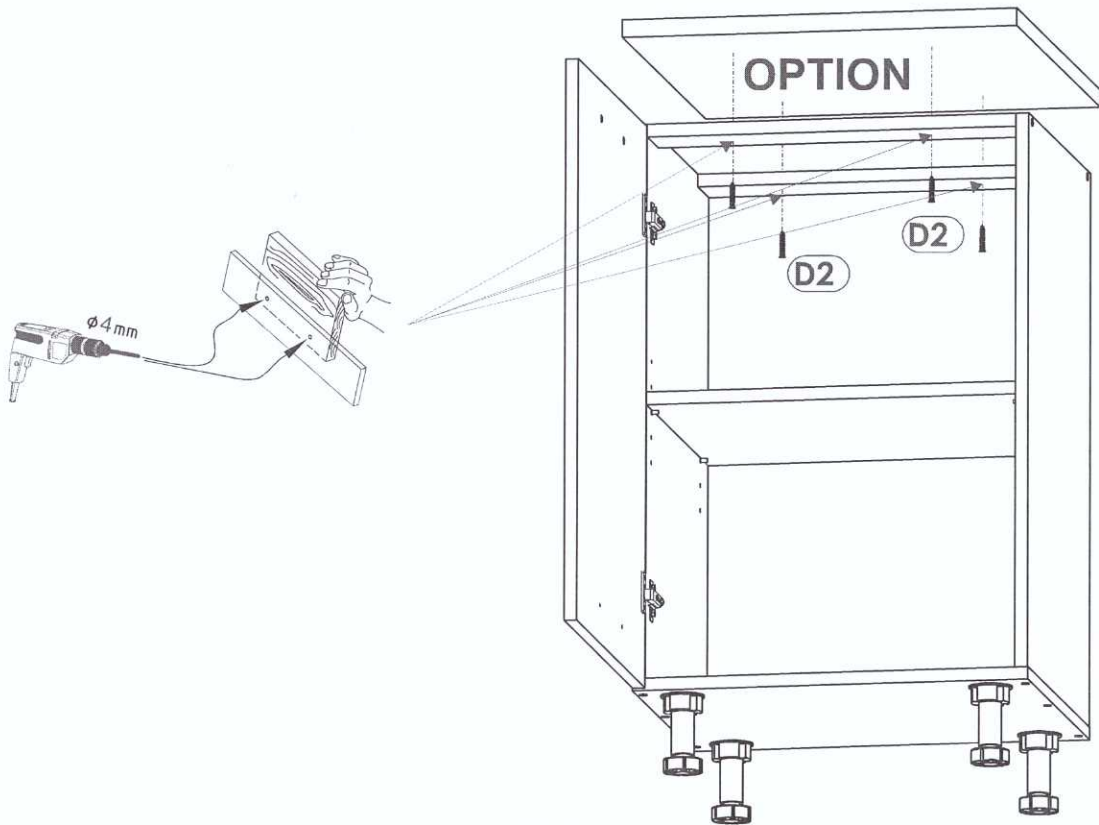

8 ▶

