

**CAUTION:**

To clean use soft, dry cloth. Do not use detergent or chemicals  
Avoid contact with water and direct sunlight.  
To be assembled on a soft, dry, clean and smooth surface.

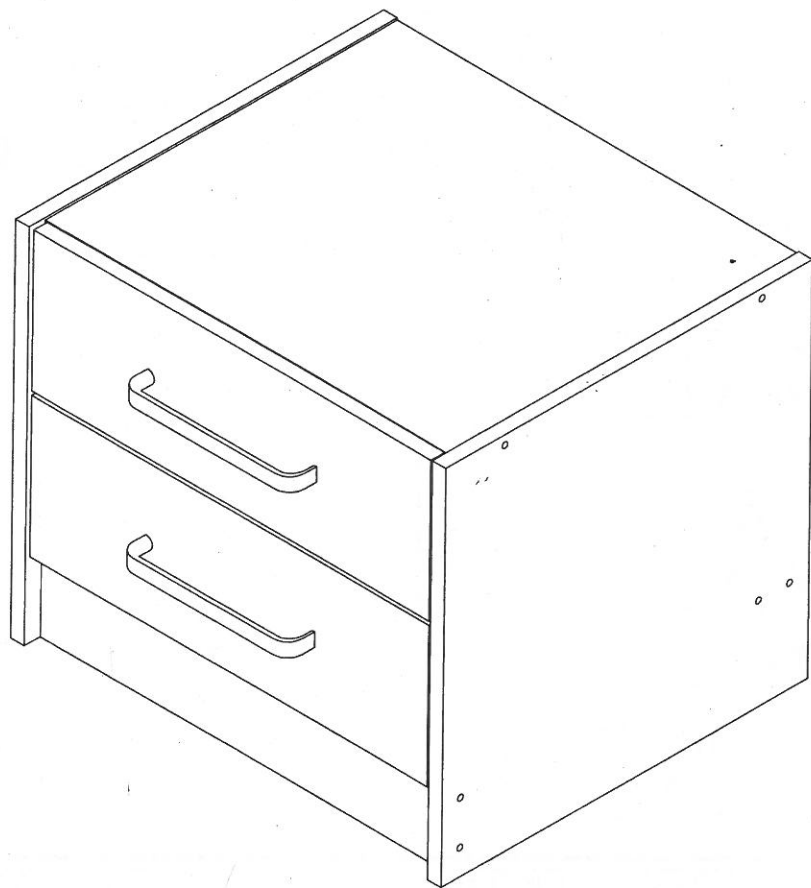

**COMPLETE SET**

**ORDERING REPAIR PARTS**

In order to obtain smooth and rapid service when ordering repair parts,  
please give full attention to the following of PART NUMBER.

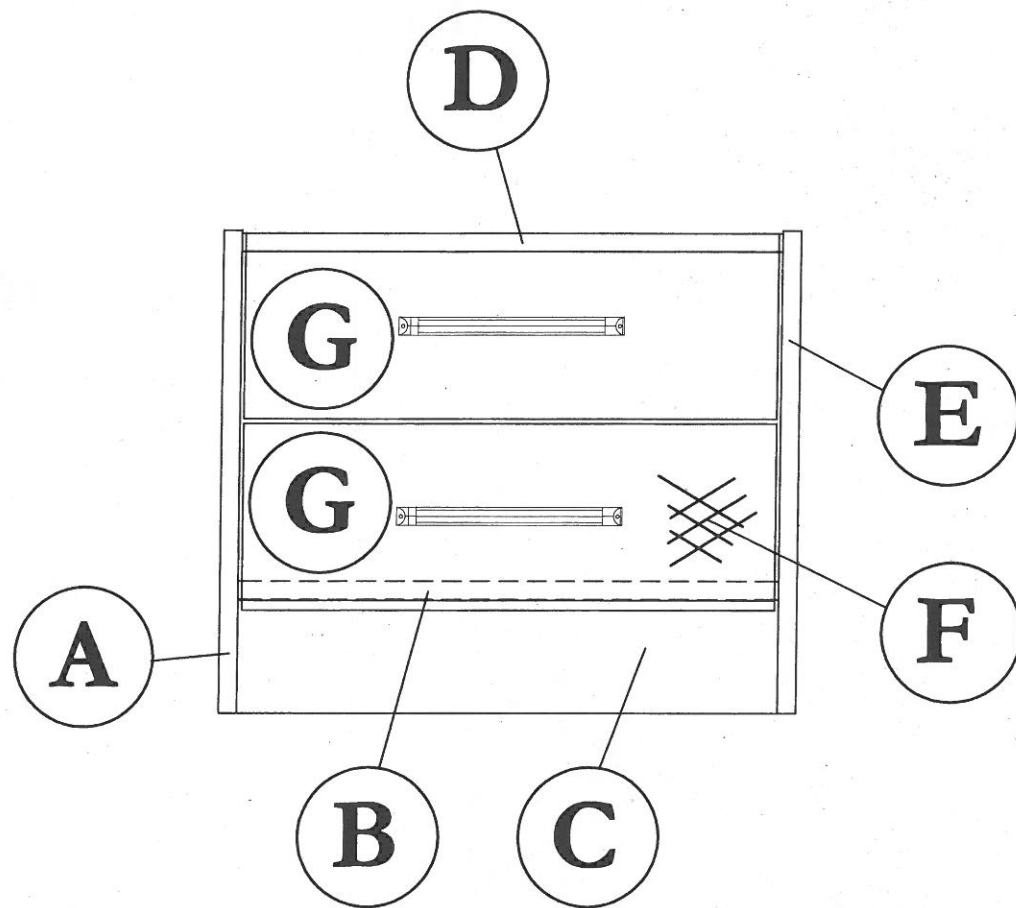

NO	DESCRIPTION	QTY
A	LEFT SIDE	01
B	LOWER SHELF	01
C	LEG	01
D	UPPER SHELF	01

NO	DESCRIPTION	QTY
E	RIGHT SIDE	01
F	BACK	01
G	DRAWER FACE	02

**ASSEMBLY INSTRUCTION**  
**MODEL : 5066 / SIDE TABLE**

Before you begin, please follow assembly instruction carefully.  
 Then follow them step by step.

**STEP 1**

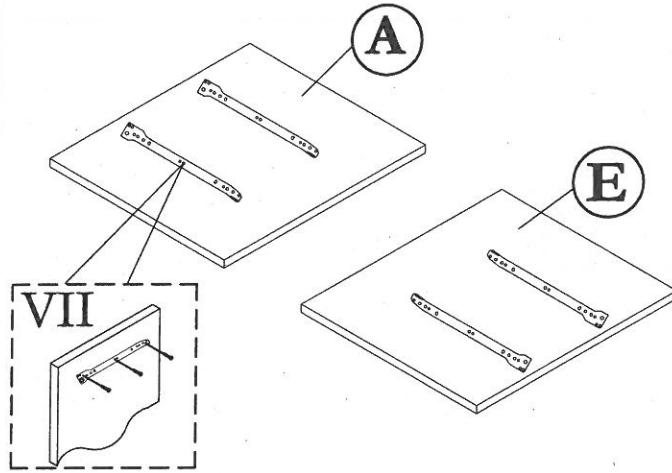

**STEP 2**

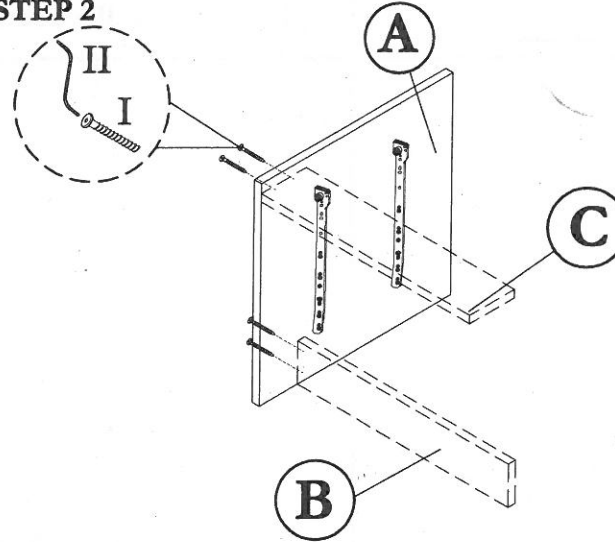

**STEP 3**

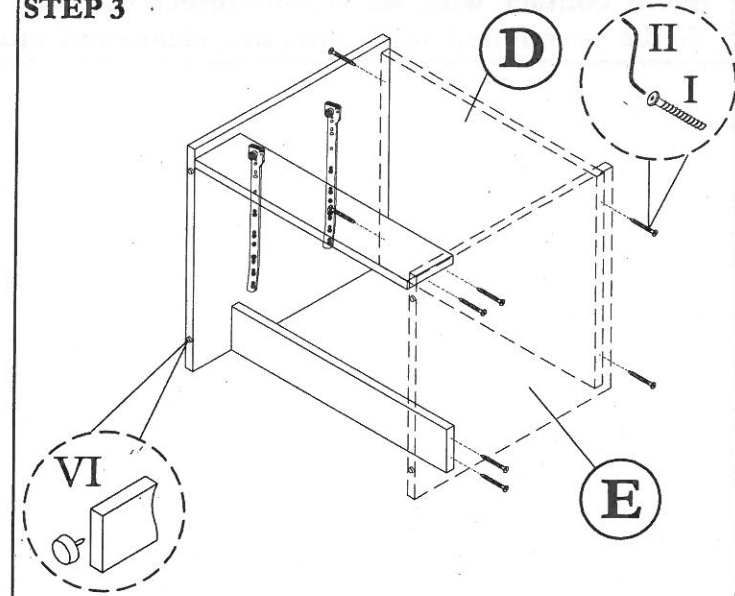

**STEP 4**

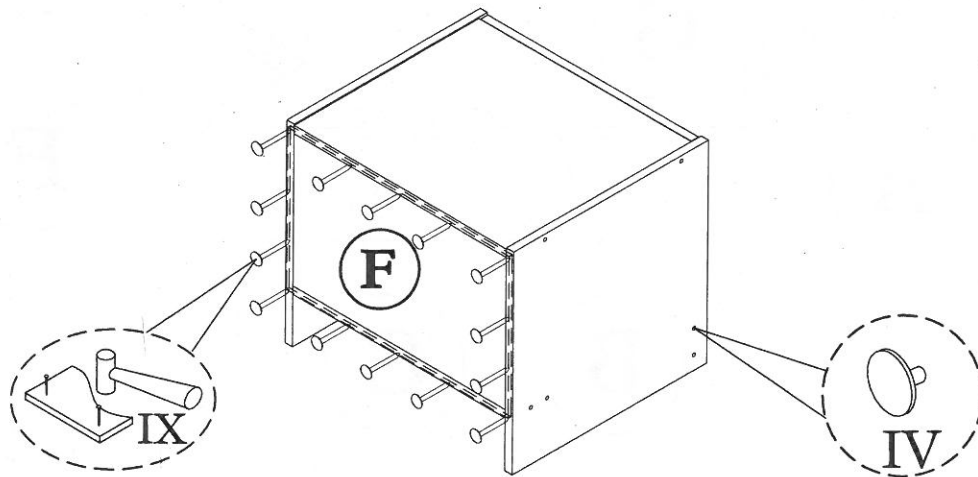

**STEP 5**

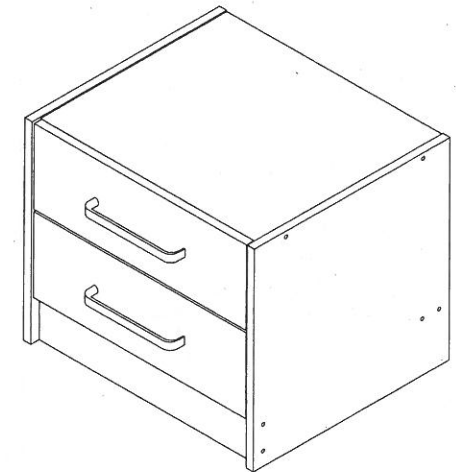
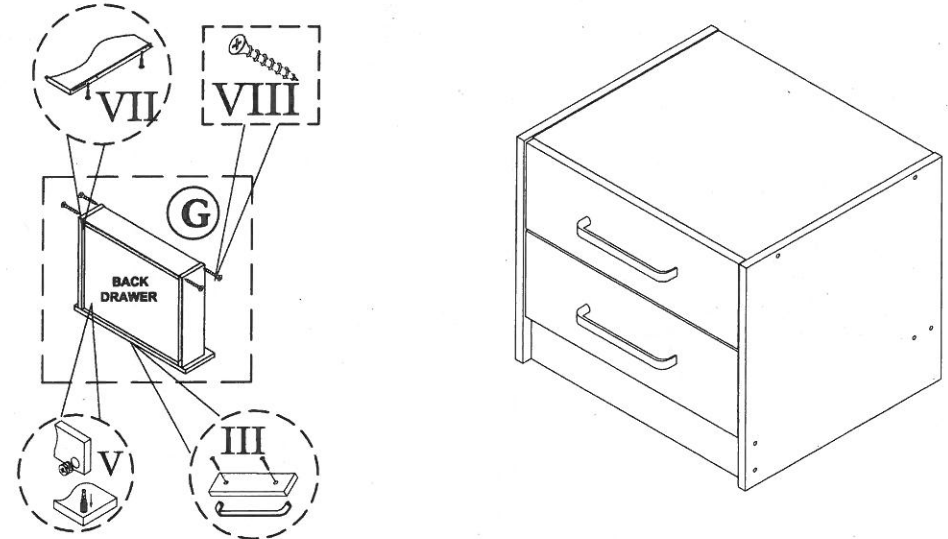

**HARDWARE LIST**

NO	DESCRIPTION	QTY
I	JCBCW SCREW M6 x 45	12pcs
II	M4 ALLEN KEY	1pc
III	HANDLE & SCREW M3.5 x 30	2sets

IV	CAP SMALL	12pcs
V	Q-FIT	8sets
VI	PVC NAIL WITH PIN	4pcs
VII	DRAWER SLIDER & SCREW M3.5 x 12	2sets
VIII	M8 X 32 CHIPBOARD SCREW	8pcs

IX	NAIL	20pcs